

LifeFitness

**Independent Stairclimbers®
SC95, SC91, SC85, S9I,
95Si, 93Si, 90S, and 95Se**

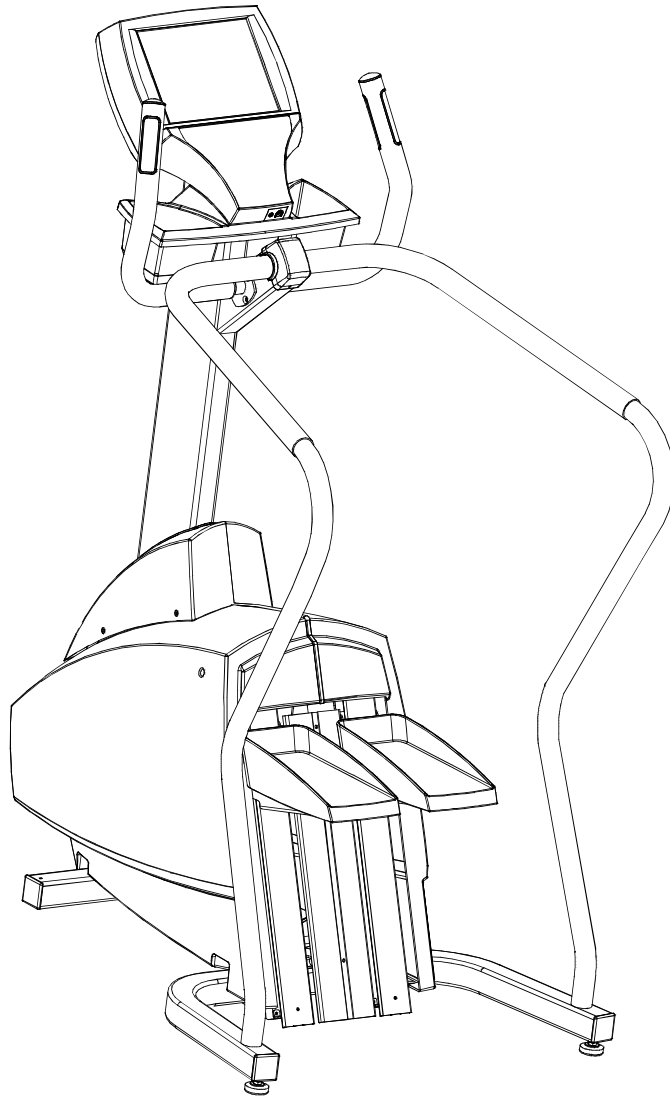

**Customer Support Services
SERVICE MANUAL**

GENERAL CONTENTS

INTRODUCTION ii
SPECIAL SERVICE TOOLS iii
GLOSSARY iv

<i>SECTIONAL CONTENTS</i>	
TROUBLESHOOTING	1
DIAGNOSTICS LED	2A
DIAGNOSTICS LCD	2B
HOW TO...SERVICE	3
ELECTRONICS	4
MISCELLANEOUS	5

Independent Stairclimbers SC95, SC91, SC85, S9i, 95Si, 93Si, 90S, and 95Se

INTRODUCTION

This service manual is applicable to Independent Stairclimbers SC95, SC91, SC85, S9i, 95Si, 93Si, 90S, and 95Se. Information represents typical configuration and may differ slightly from actual equipment. The service manual provides recommendations for safe and efficient approaches.

If an operating problem should arise, turn to the TROUBLESHOOTING GUIDES and attempt to isolate what is causing the malfunction. The GUIDES are listed by symptoms and follow with suggestions as to the most probable cause of the problem.

Once you have pinpointed the source of the problem, turn to the appropriate "how to..." Section and review the proper procedures for removing, replacing or adjusting a part. The "how to..." Sections are organized by replaceable part (or assembly) name and each page lists the "special tools required" to complete the specific task.

If you do not have a part in stock, a form to order by FAX has been included in Section V for your convenience or you can call Life Fitness Customer Support Services any Monday through Friday from 8:00 AM to 6:00 PM (CST). When you place a call, in order to speed our response to your particular situation, please have the following information available for the customer service phone technician who will be prepared to assist you:

1. The Lifecycle equipment model number
2. The serial number
3. The symptom of the problem
4. The part name and number to order

When you receive your order, review the appropriate "How To..." section and follow the step by step procedures designed to help you install the part quickly and correctly.

If you have any questions or comments please phone, mail, or fax us at:

LIFE FITNESS COMPANY - CUSTOMER SUPPORT SERVICES
10601 Belmont Avenue, Franklin Park, IL 60131; U.S.A.
Telephone: 847-451-0036, Toll Free: 800-351-3737, FAX: 847-288-3702

Independent Stairclimbers SC95, SC91, SC85, S9i, 95Si, 93Si, 90S, and 95Se
SPECIAL SERVICE TOOL REQUIRED

Unless otherwise specified, only basic hand tools are required to perform service procedures outlined in this section. Some of these standard tools should consist of: Philips and Straight-Blade Screw Drivers, Torx Set, Pliers, Rubber Mallet, Pry Bar, Snap Ring Pliers (internal and external), Standard and Metric size Socket Set (3/8 or 1/2 drive), and Standard and Metric size Combination, open-end, or Box Wrenches.

Specialized tools will be listed after the sub-heading **Special Service Tools:**, which appears below the Service Procedure Heading at the top of the page. If no specialized tools are required, then the title would read: **Special Service Tools: NONE**, which means that standard hand tools should be employed to provide service to the product.

Specialized tools must be used to safely and effectively complete the service procedures. Improvisation or attempts to use any other tool could result in unnecessary damage to the equipment or personal injury.

GLOSSARY

SECTION I

TROUBLESHOOTING GUIDES

	Page
Grinding Noise	3
Slipping and Squealing	3
Burning Smell.....	3
Pedals Resting on Floor.....	3
Slow Pedal Return.....	3
No Power.....	4
Battery Drain	4
Display Console Doesn't Illuminate.....	4
Display Console Dim.....	5
Display Console Illuminates, then goes dark	6
Heart Rate Inoperative	6
Life Pulse Sensors Loose	6
Erratic Heart Rate Display.....	6
Telemetry Inoperative.....	7
Unit Pauses Unexpectedly	7
Display Step Activity Inaccurate	7
Load Resistance Varies	7
Unable to Change Audio	8
No Audio to Headphone	8
Unable to Receive any Stations when using Cable.....	8
TV Picture Snowy.....	8
LCD Screen Illuminates but is blank	8
LCD Screen is dark	8
Screen Doesn't Respond	8
Erratic Touch Screen Operation.....	8
Testing the Inverter Board.....	9
Testing the Power Supply Cable	10

**Independent Stairclimbers SC95, SC91, SC85, S9i, 95SI, 93SI, 90S, and 95SE
TROUBLESHOOTING GUIDE**

NOTES

Independent Stairclimbers SC95, SC91, SC85, S9i, 95Si, 93Si, 90S, and 95Se
TROUBLESHOOTING GUIDE

SYMPTOM	PROBABLE CAUSE	CORRECTIVE ACTION
Grinding noise during operation	Clutch roller bearings worn excessively	If necessary, replace clutch assembly.
	Crossover pulley bearings worn excessively	Inspect crossover pulley bearings for excessive wear or binding. If necessary, replace crossover pulley.
	Alternator bearings worn excessively	Remove alternator and drive belts. Spin alternator flywheel and listen/feel for roughness. If necessary, replace alternator.
	Main drive shaft bearings worn excessively	Remove alternator and drive belts. Inspect main drive shaft bearings for excessive wear. If necessary, replace bearings.
	Pedal roller bearings worn excessively	Inspect all roller bearings for excessive wear or binding. If necessary, replace rollers.
Slipping or squealing noise	Main drive belt loose or worn excessively	Adjust or replace belt.
	Alternator belt loose or worn excessively	Adjust or replace belt.
	Belt spring assembly worn excessively	If necessary, replace belt spring.
	Clutch roller bearings worn excessively	If necessary, replace clutch assembly.
Burning odor when functioning	Alternator belt tension too low	Adjust alternator belt tension.
	New machine	A new Stairclimber® may emit a slight odor during the first few hours of operation as the load resistor heats up for the first few times. If odor persists, contact customer service.
Pedals resting on floor	Belt spring assembly broken	If necessary, replace belt spring assembly.
Slow pedal return	Pedal roller bearings worn excessively	If necessary, replace rollers.
	Belt/spring assembly binding	If necessary, replace pulley.
	Clutches binding	Check clutch operation to make sure there is no binding in the free-spinning direction. If necessary, replace clutch.
	Back side idler gap too tight	Check for minimum gap of 1/16" between the back side idler and belt. If necessary, replace bent or damaged components as needed.

Independent Stairclimbers SC95, SC91, SC85, S9i, 95Si, 93Si, 90S, and 95Se
TROUBLESHOOTING GUIDE

SYMPTOM	PROBABLE CAUSE	CORRECTIVE ACTION
Unit will not allow lighter weight user to reach higher level	Main drive belt tension excessive	Adjust main drive belt tension.
No power	Faulty battery (SC95, SC91 and SC85)	Verify battery pack voltage is minimum of 6VDC. If necessary, replace battery pack.
	Faulty AC Adapter (SC91 and 93Si only)	Verify AC adapter supplies 9VDC(+/- 0.3V). If necessary, replace AC adapter.
	Faulty reed switch	Position magnet away from reed switch. Verify continuity between pin #2 and #3. Verify an open connection between pin #1 and #3. Reposition magnet close to reed switch. Verify an open circuit between pin #2 and #3, and continuity between pin #1 and #3. If necessary, replace reed switch.
	Faulty battery charger (SC95, 95Si, SC91, 93Si, SC85, and 90S)	Output voltage of charger should be 6VDC(+/-0.3V). If necessary, replace charger.
	Reed switch improperly positioned	Verify reed switch is in correct position.
Battery runs down	Stepping rate extremely slow	Increase step rate. Use optional charger.
	Stairclimber® is consistently used by lighter (less than 120 lbs.) Users and workout duration's are consistently less than 20 minutes, or usage is less than 2 hours per day	Charge unit overnight at least once per week to ensure a long life for the battery.
	Not enough downward force on pedals	Eliminate resting majority of body weight on handlebars.
	Faulty battery pack	Charge battery overnight. Verify that battery voltage is 6VDC (+/-0.3V). If necessary, replace battery pack.
Display console doesn't illuminate	Faulty reed switch	Position magnet away from reed switch. Verify continuity between pin #2 and #3. Verify an open connection between pin #1 and #3. Reposition magnet close to reed switch. Verify an open circuit between pin #2 and #3, and continuity between pin #1 and #3. If necessary, replace reed switch.
	Reed switch improperly positioned	Verify reed switch is properly positioned in relation to magnet.

Independent Stairclimbers SC95, SC91, SC85, S9i, 95Si, 93Si, 90S, and 95Se
TROUBLESHOOTING GUIDE

SYMPTOM	PROBABLE CAUSE	CORRECTIVE ACTION
Display console doesn't illuminate	Faulty display console	Verify voltages at display console connections. Substitute a working display console. If necessary, replace display console.
	Faulty alternator control board	Verify connections between display console and alternator control board. Substitute a working alternator control board. If necessary, replace alternator control board.
	Faulty battery charger (SC95, 95Si, SC91, 93Si, SC85, and 90S)	Output voltage of charger should be 6VDC(+/-0.3V). If necessary, replace charger.
	Faulty AC Adapter (SC91 and 93Si only)	Verify AC adapter supplies 9VDC(+/-0.3V). If necessary, replace AC adapter.
	Faulty connection	Verify connections at display console and alternator control board. Repair connections.
	Faulty wiring harness	Verify continuity of main wire harness. If necessary, replace wire harness.
	Battery pack requires recharge	Charger should be connected for a minimum of eight hours to ensure a thorough recharge.
	Faulty battery pack	Charge battery overnight. Verify that battery voltage is 6VDC (+/-0.3V). If necessary, replace battery pack.
Display console dim	Faulty display console	Verify voltages at display console connections. Substitute a working display console. If necessary, replace display console.
	Faulty alternator control board	Verify connections between display console and alternator control board. Substitute a working alternator control board. If necessary, replace alternator control board.
	Faulty battery charger (SC95, 95Si, SC91, 93Si, SC85, and 90S)	Output voltage of charger should be 6VDC(+/-0.3V). If necessary, replace charger.
	Faulty AC Adapter (SC91 and 93Si only)	Verify AC adapter supplies 9VDC(+/-0.3V). If necessary, replace AC adapter.

Independent Stairclimbers SC95, SC91, SC85, S9i, 95Si, 93Si, 90S, and 95Se
TROUBLESHOOTING GUIDE

SYMPTOM	PROBABLE CAUSE	CORRECTIVE ACTION
Display console dim	Worn overlay bezel assembly	Perform keypad test. If necessary, replace display console.
	Faulty display console	Verify voltages at display console connections. Substitute a working display console. If necessary, replace display console.
Display console illuminates, then goes dark	Insufficient battery voltage	Verify battery pack voltage is minimum of 6VDC.
	Faulty connection	Verify connections and voltages between display console and alternator control board. Repair connections.
	Faulty display console	Verify voltages at display console. Substitute a working display console. If necessary, replace display console.
	Faulty alternator control board	Verify connections between display console and alternator control board. Substitute a working alternator control board. If necessary, replace alternator control board.
	Faulty battery charger (SC95, 95Si, SC91, 93Si, SC85, and 90S)	Output voltage of charger should be 6VDC(+/-0.3V). If necessary, replace charger.
	Faulty AC Adapter (SC91/93Si only)	Verify AC adapter supplies 9VDC(+/-0.3V). If necessary, replace AC adapter.
Heart rate inoperative	Faulty connection	Verify connections between display console and LifePulse® sensors. Repair connections.
	Faulty LifePulse® sensors	Verify LifePulse® sensors are functioning correctly. If necessary, replace sensors.
	Faulty display console	Verify voltages at display console connections. Substitute a working display console. If necessary, replace display console.
LifePulse® sensors loose	Cleaning solution that contained a caustic chemical has possibly been used.	If necessary, replace LifePulse® sensors.
Erratic heart rate display	Cleaning solution that contained a caustic chemical has possibly been used.	Check for Loose LifePulse® sensors. If necessary, replace LifePulse® sensors.
	Sensors dirty	Clean sensors with a solution of mild soap and water.

Independent Stairclimbers SC95, SC91, SC85, S9i, 95Si, 93Si, 90S, and 95Se
TROUBLESHOOTING GUIDE

SYMPTOM	PROBABLE CAUSE	CORRECTIVE ACTION
Telemetry inoperative	Chest strap not making good contact with body of user	Adjust chest strap tightness. Moisten sensor for better contact with skin.
	Faulty connection	Verify connections between Polar® receiver and display console. Repair connections.
	Faulty transmitter or receiver	Verify Polar® transmitter (chest strap) and receiver for proper operation. (pulse simulator required)
	Telemetry option disabled	Enable telemetry.
	User is out of monitoring range	Move within three feet (1 meter) of receiver.
Unit pauses unexpectedly	RPM signal loss	Verify integrity of RPM_ALT signal between alternator and alternator control board.
Displayed step activity inaccurate	Insufficient pedal travel	Increase pedal travel during operation.
	Faulty connection	Verify connections between display console, alternator control board, and alternator. Repair connections.
	Faulty alternator brushes	Inspect alternator brushes. Brushes should be of approximate equal length, not cracked, or less than ¼" long. If necessary, replace faulty alternator brushes.
	Faulty alternator	If necessary, replace alternator.
	Faulty alternator control board	Verify connections between display console and alternator control board. Substitute a working alternator control board. If necessary, replace alternator control board.
Load resistance varies during operation	Faulty connection	Verify connections between display console, alternator control board, and alternator. Repair connections.
	Faulty alternator harness	Verify integrity of harness between alternator and alternator control board.
	Faulty alternator	If necessary, replace alternator.
	Faulty alternator brushes	Inspect alternator brushes. Brushes should be of approximate equal length, not cracked, or less than ¼" long. If necessary, replace faulty alternator brushes.

Independent Stairclimbers SC95, SC91, SC85, S9i, 95Si, 93Si, 90S, and 95Se
TROUBLESHOOTING GUIDE

SYMPTOM	PROBABLE CAUSE	CORRECTIVE ACTION
Load resistance varies during operation	Faulty alternator control board	Verify connections between display console and alternator control board. Substitute a working alternator control board. If necessary, replace alternator control board.
	Faulty display console	Verify voltages at display console connections. Substitute a working display console. If necessary, replace display console.
Unable to change audio level	Faulty Keypad	Perform keypad diagnostic.
	Faulty interface board	If necessary, replace Interface board.
No audio to headphones	Faulty headphone	If necessary, replace headphone assembly.
	Faulty headphone jack	If necessary, replace headphone jack assembly.
	Faulty headphone jack cable	If necessary, replace headphone cable assembly.
	Faulty computer board	If necessary, replace computer board.
	Faulty interface board	If necessary, replace Interface board.
Unable to receive any stations when using cable	Air/cable setting may be incorrect	Refer to TV configuration.
	Faulty coaxial cable	If necessary, replace coaxial cable.
TV picture has “snow like” appearance	Air/cable setting may be incorrect	Refer to TV configuration.
	Faulty coaxial cable	If necessary, replace coaxial cable.
LCD screen illuminated but blank	Faulty LCD backlight	If necessary, replace touch screen.
	Faulty backlight power inverter	If necessary, replace inverter board.
	Faulty LCD screen	If necessary, replace touch screen.
	Faulty computer board	If necessary, replace computer board.
LCD screen is dark	Faulty LCD backlight	If necessary, replace touch screen.
	Faulty backlight power inverter	If necessary, replace inverter board.
Screen doesn’t respond to touch	Faulty touch screen	If necessary, replace touch screen.
	Faulty computer board	If necessary, replace computer board.
Erratic touch screen operation	Touch screen not properly calibrated	Calibrate touch screen.

Independent Stairclimbers SC95, SC91, SC85, S9i, 95Si, 93Si, 90S, and 95Se
TROUBLESHOOTING GUIDE – TESTING THE INVERTER BOARD

Special Service Tools Required: Multi-meter

CAUTION! HIGH VOLTAGE ON CONNECTORS J2 AND J3

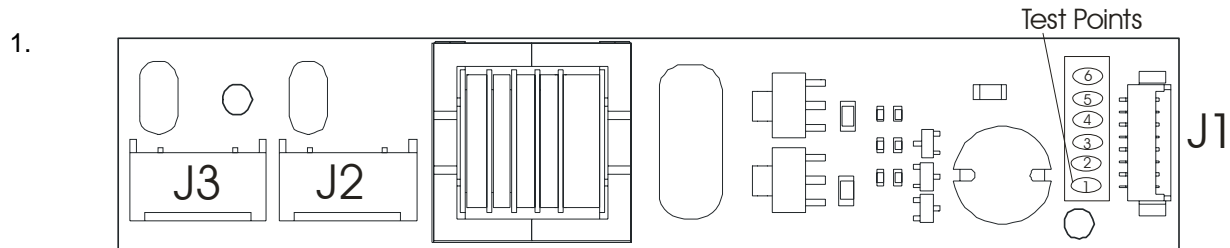

Remove the Entertainment System Console from the Unit.

2. Remove Rear Cover from the Console Assembly.
3. Plug in Power Supply and Remote Control to the Console
4. Press the Power On Key on the Remote Control.
5. TEST NO. 1: Place the Red Lead from the multi-meter onto Test Point 1 and the Black Lead onto Test Point 3. Voltage should be 12 Vdc (+/- .5V).
6. TEST NO. 2: Place the Red Lead from the multi-meter onto Test Point 5 and the Black Lead to Test Point 3. Voltage should be 12 Vdc (+/- .5V)

PROBLEM	SOLUTION
No Voltage on TP1	Replace Cable, Remote, or Main PC Board.
Voltage present on TP1	Replace the Inverter Board
Voltage on TP1 and TP2 but NO Voltage on TP5	Replace Cable between Inverter Board and Main PC Board

TEST POINT	VOLTAGE	DESCRIPTION	PIN NUMBER
TP 1 & 2	12 Vdc	VIN	1 & 2
TP 3 & 4	0 Vdc	Ground	3 & 4
5	12 Vdc	Enable	5
5	0 Vdc	Disable	5
6	Not Used	Not Used	6/7/8

Independent Stairclimbers SC95, SC91, SC85, S9i, 95Si, 93Si, 90S, and 95Se
TROUBLESHOOTING GUIDE – TESTING THE POWER SUPPLY CABLE

Special Service Tools Required: Multi-meter

1. Unscrew the Retaining Nut securing the Power Cable Plug. Remove the Cable.
2. Using a Multi-meter, touch the Red Lead to the POSITIVE area on the Cable, which is the center of the cable. Next touch the Black Lead to the NEGATIVE area, which is the side of the inner Cable. The voltage should read 12 Vdc.

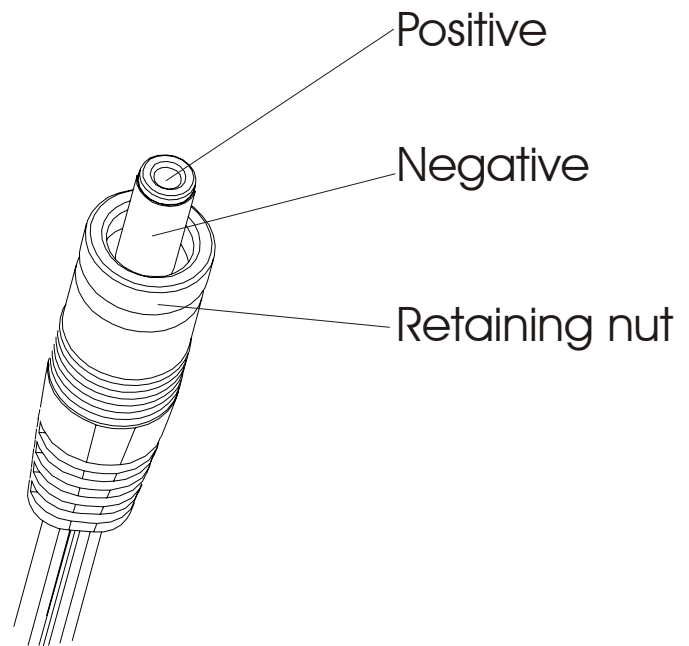

SECTION II

DIAGNOSTIC MODES FOR LED UNITS

	Page
SC9500 and 95Si Console	3
SC9100 and 93Si Console	4
SC8500 and 90S Console	5
S9i Console.....	6
Diagnostic Functional MAP.....	7
ENTRY LEVEL.....	8
Test/Service - All LEDs And Keypad Test.....	9
Test/Service - Walking LED Test.....	10
Test/Service – Alternator and Speaker Test.....	11
Test/Service – System Voltage and Step Rate Monitoring	12
Test/Service – Signal Integrity Test.....	13
Test/Service - Life Pulse Test.....	14
Test/Service - CSAFE Network InterfaceTest	15
Test/Service - EEPROM Test.....	16
Test/Service - Telemetry Enable/Disable	17
Test/Service - Language.....	18
Optional Settings - MAX Workout Duration	19
Optional Settings - English/Metric Units	20
Optional Settings - WATT Display Enable/Disable.....	21
Optional Settings - METS Display Enable/Disable.....	22
Optional Settings - CAL/HR Display Enable/Disable.....	23
Optional Settings - METS Program Enable/Disable.....	24
Optional Settings – Total Hours and Statistics	25
Optional Settings - Entertainment controls.....	26
Optional Settings - Photo Shoot	27
Notes.....	28

Independent Stairclimbers SC95, SC91, SC85, S9i, 95Si, 90S, and 95Se

Notes

Independent Stairclimbers SC95, SC91, SC85, S9i, 95Si, 90S, and 95Se DISPLAY CONSOLE SC9500 and 95Si

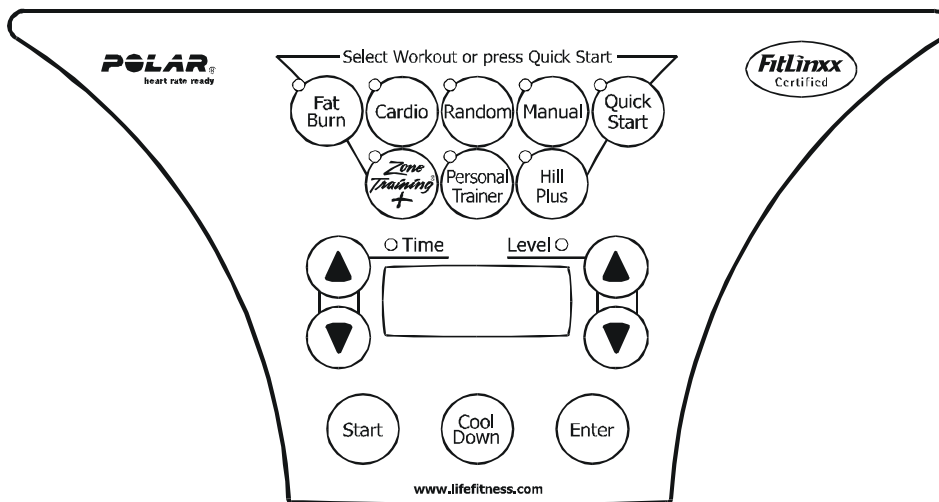
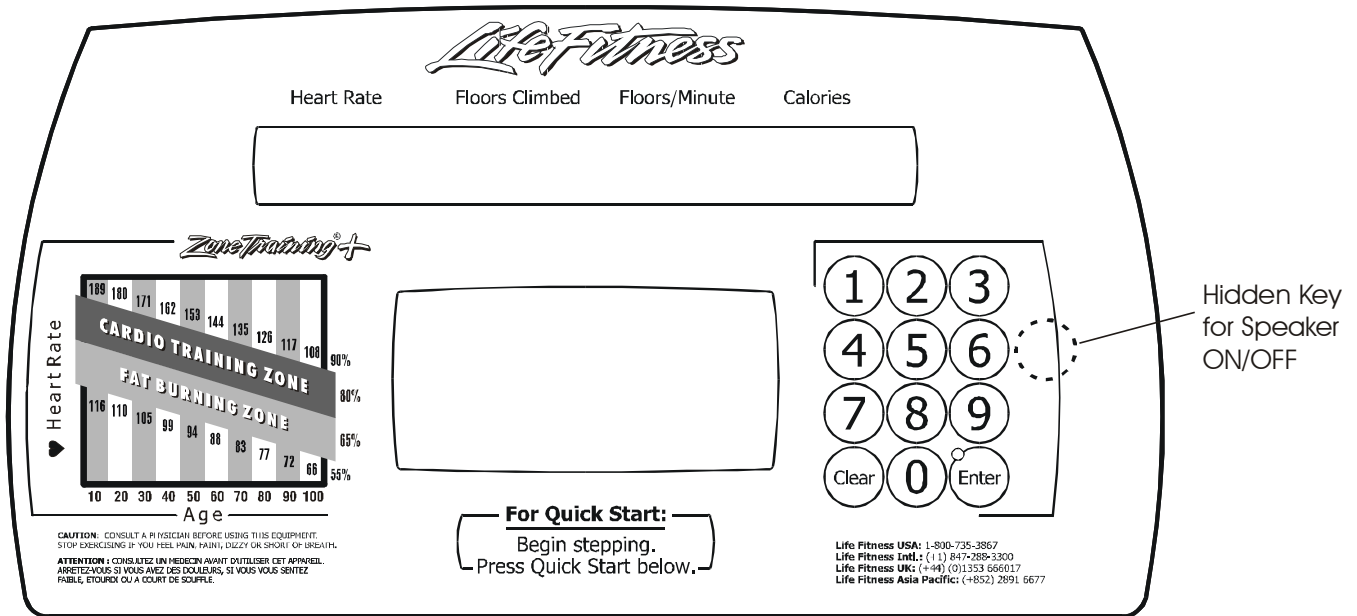

Independent Stairclimbers SC95, SC91, SC85, S9i, 95Si, 90S, and 95Se DISPLAY CONSOLE SC9100 and 93Si

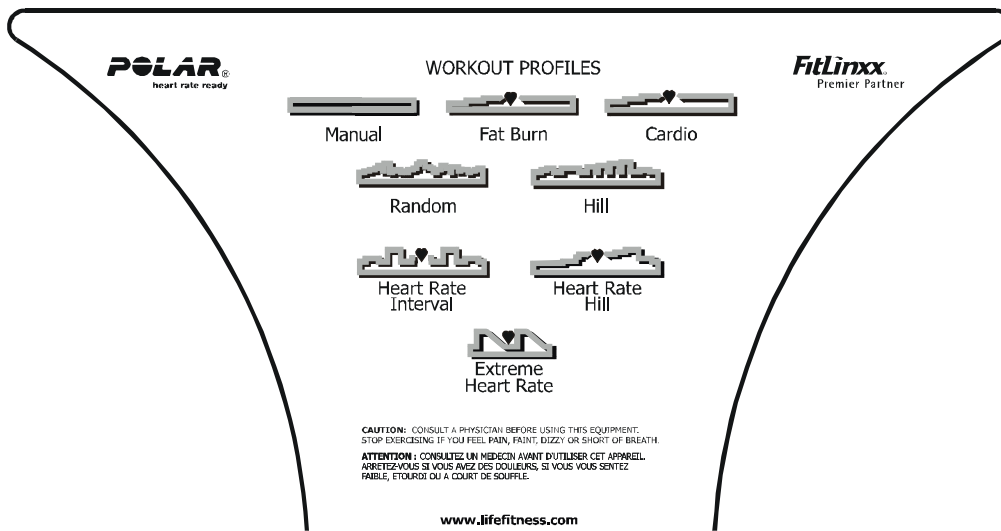
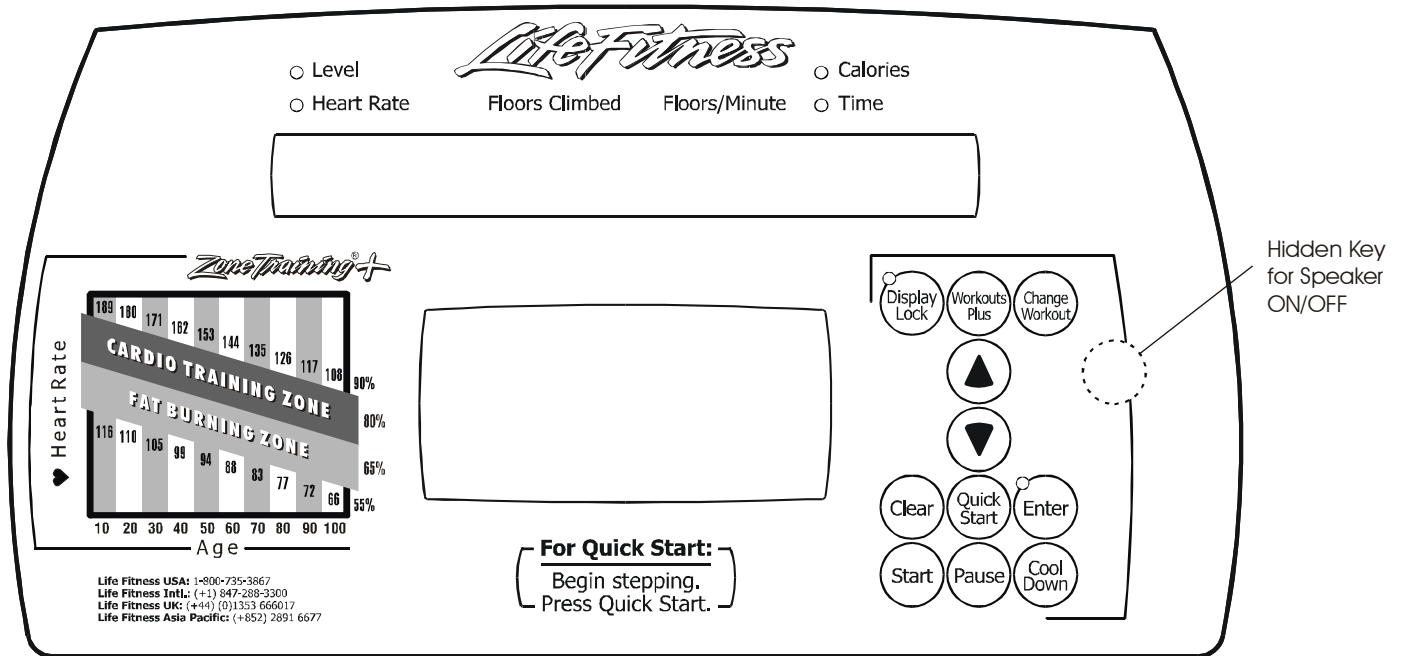

**Independent Stairclimbers SC95, SC91, SC85, S9i, 95Si, 90S, and 95Se
DISPLAY CONSOLE SC8500 and 90S**

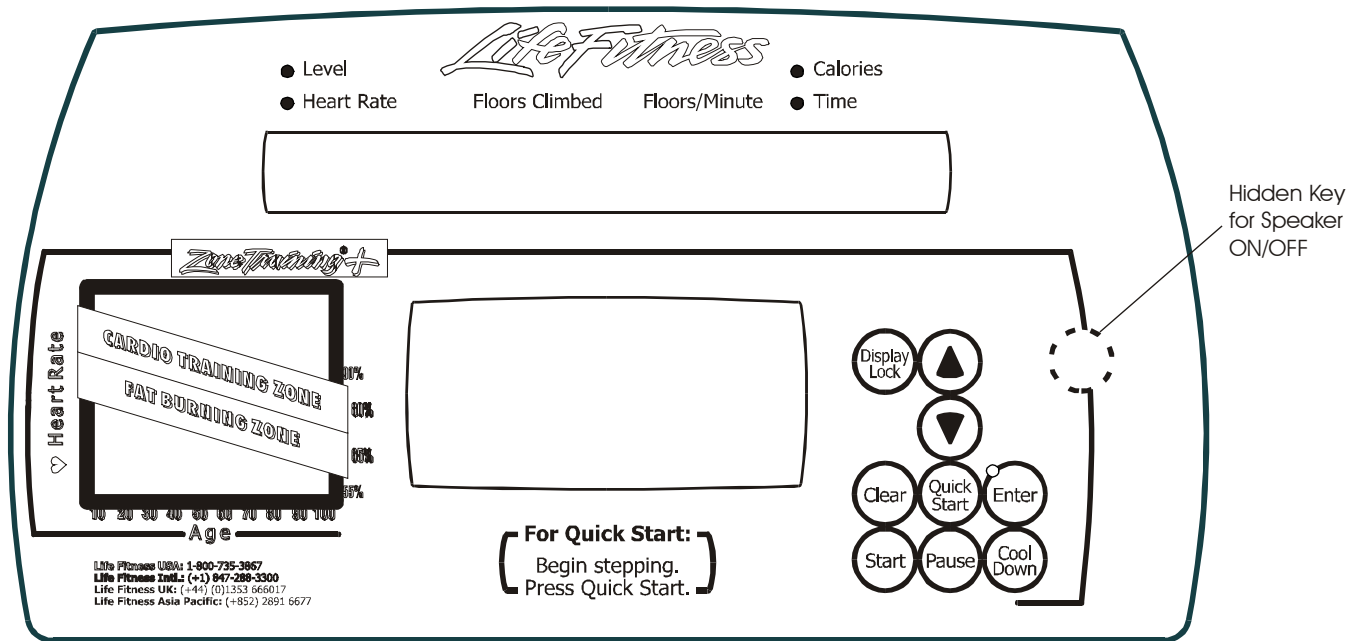

**Independent Stairclimbers SC95, SC91, SC85, S9i, 95Si, 90S, and 95Se
Diagnostic Functional MAP (LED Integrated)**

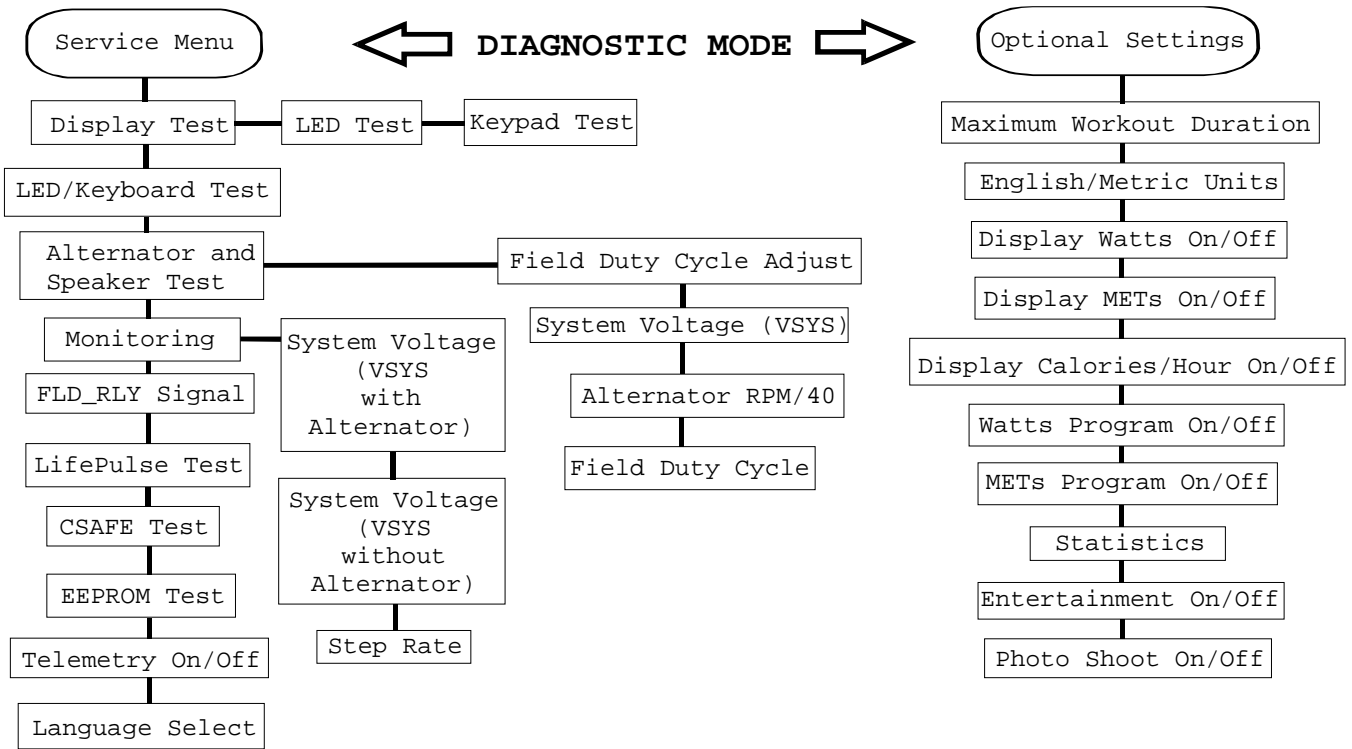

Independent Stairclimbers SC95, SC91, SC85, S9i, 95Si, 90S, and 95Se
ENTRY LEVEL

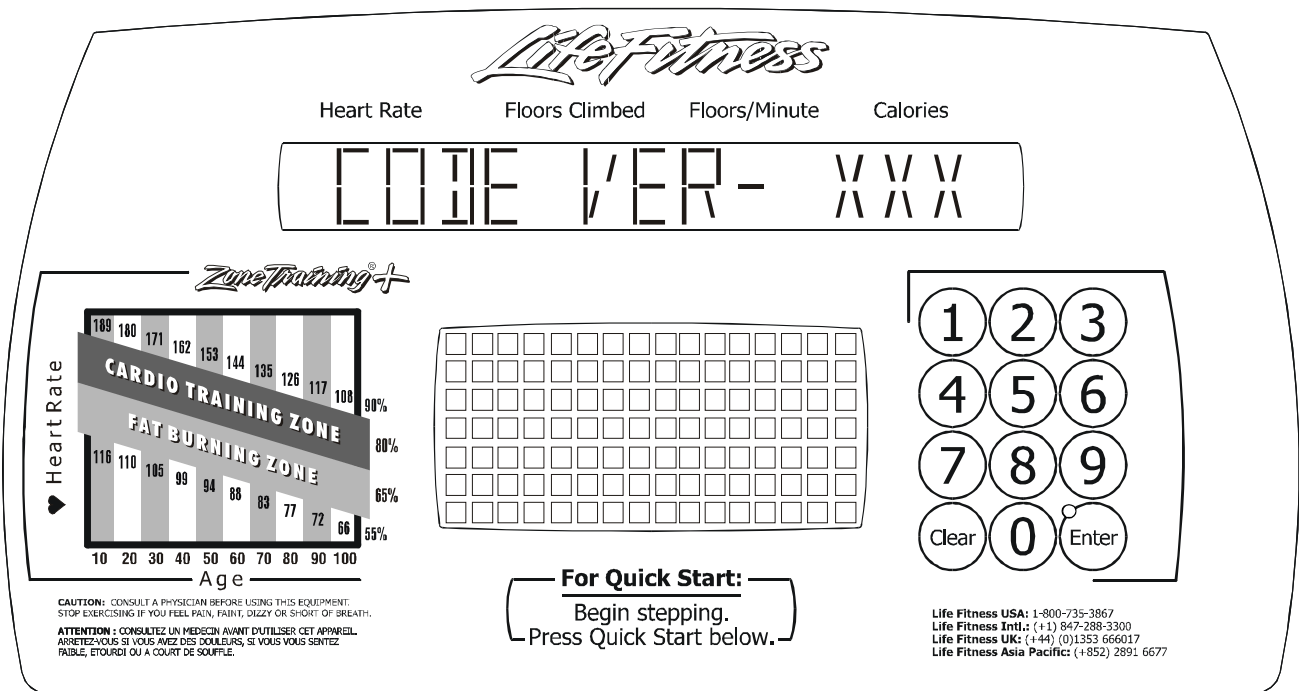

Hold down the number 5 key (SC9500 and 95Si) or the UP ARROW key on (all other models), then press the CLEAR key twice. Press the up ARROW key. The display menu will show after each press:

CODE VERSIONex: **CODE VER - X.XX**
 CSAFE VERSIONex: **CSAFE ver-- X.XX.XX**
 PART NUMBERex: **XXXX-- XXXXX--0000**
 BOOT LOADER VERSION.....ex: **BOOT VER -- X - (9500 models Only)**

Press and hold COOL DOWN, key and then press ENTER for entry into the **SERVICE MENU**.
 Press ENTER for entry into the **OPTIONAL SETTINGS**.

Press the ENTER Key to advance to the next diagnostic state.
 Press the CLEAR Key to return to the previous diagnostic state.
 Exit the diagnostic state by pressing the CLEAR Key until the display reads SELECT WORKOUT.

Independent Stairclimbers SC95, SC91, SC85, S9i, 95Si, 90S, and 95Se
TEST/SERVICE ALL LEDs AND KEYPAD TEST

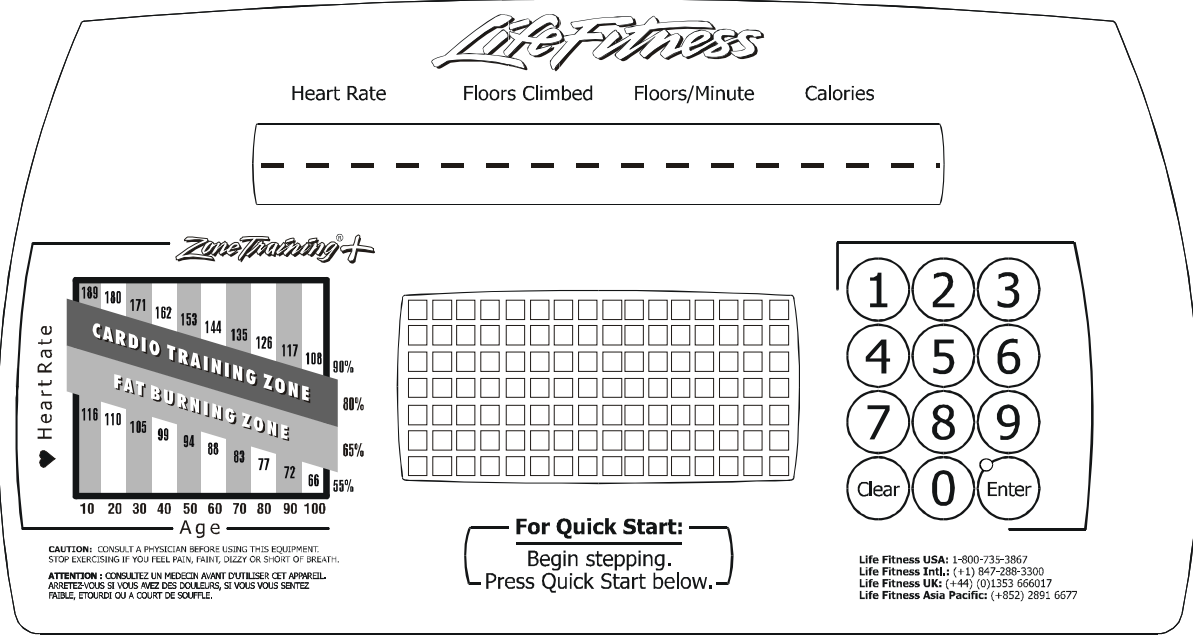

Upon entry to this state, all of the LED's will turn ON. Pressing the keys will result in a beep sound for all but the START, ENTER and CLEAR keys, a character repeated across the message center will be displayed.

KEYS	DISPLAYED CHARACTER	KEYS	DISPLAYED CHARACTER
0	0	Display Lock	L
1	1	Workouts Plus	K
2	2	Change Workout	W
3	3	Up arrow	U
4	4	Down Arrow	D
5	5	Quick Start	Q
6	6	Start	S
7	7	Pause	P
8	8	Cool down	--
9	9		
TIME UP	U		
TIME DOWN	D		
LEVEL UP	▲		
LEVEL DOWN	▼		
FAT BURN	F		
CARDIO	C		
RANDOM	R		
MANUAL	M		
QUICK START	Q		
ZONE TRAINING	Z		
PERSONAL TRAINER	T		
HILL PLUS	H		
COOL DOWN	--		

Press the ENTER Key to advance to the next diagnostic state.
 Press the CLEAR Key to return to the previous diagnostic state.
 Exit the diagnostic state by pressing the CLEAR Key until the display reads SELECT WORKOUT.

Independent Stairclimbers SC95, SC91, SC85, S9i, 95Si, 90S, and 95Se
TEST/SERVICE - WALKING LED TEST

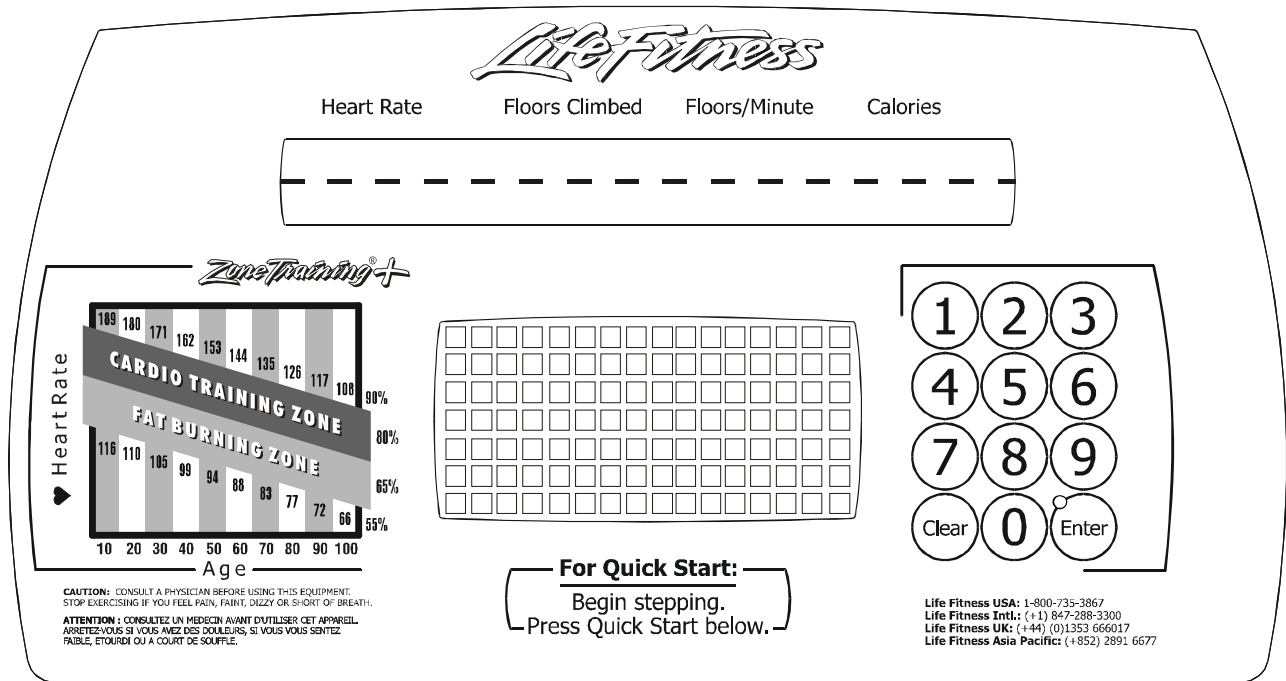

Upon entry to this state, the LED segments in the MESSAGE CENTER and the PROFILE WINDOW will give the effect of moving, or “Walking LED”.

- Press the ENTER Key to advance to the next diagnostic state.
- Press the CLEAR Key to return to the previous diagnostic state.
- Exit the diagnostic state by pressing the CLEAR Key until the display reads SELECT WORKOUT.

Independent Stairclimbers SC95, SC91, SC85, S9i, 95Si, 90S, and 95Se
TEST/SERVICE – ALTERNATOR AND SPEAKER TEST

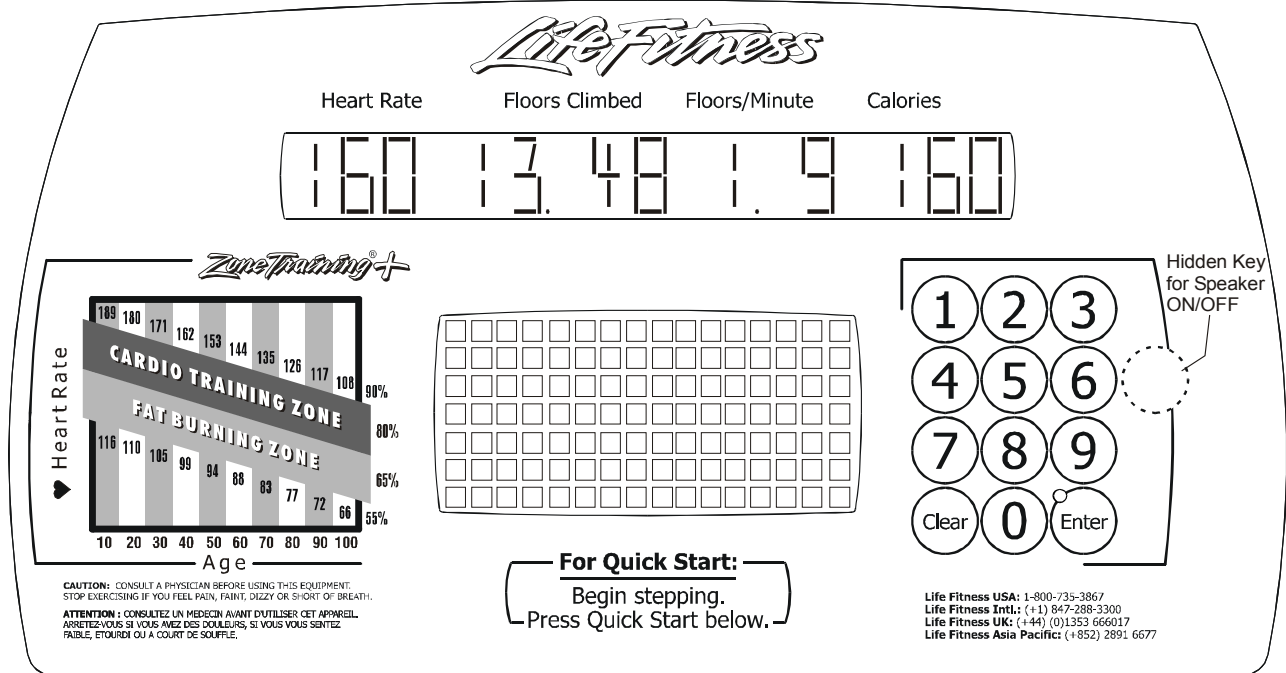

The present Field Duty Cycle being applied to the alternator is displayed in the Heart Rate and Calories Window. This value ranges from 0-255. Factory setting is 160.

The alternator Output Voltage is displayed in the Floors Climbed Window.

The step rate RPM will be displayed in the Floors/Minute window.

To test the alternator, the field duty cycle or load applied, can be increased or decreased by using the up and down arrows. Changing this value will increase or decrease the step rate load applied to the pedals.

Pressing the hidden key, as shown above, will toggle the speaker ON and OFF.

Press the ENTER Key to advance to the next diagnostic state.

Press the CLEAR Key to return to the previous diagnostic state.

Exit the diagnostic state by pressing the CLEAR Key until the display reads SELECT WORKOUT.

Independent Stairclimbers SC95, SC91, SC85, S9i, 95Si, 90S, and 95Se
TEST/SERVICE – SYSTEM VOLTAGE AND STEP RATE MONITORING

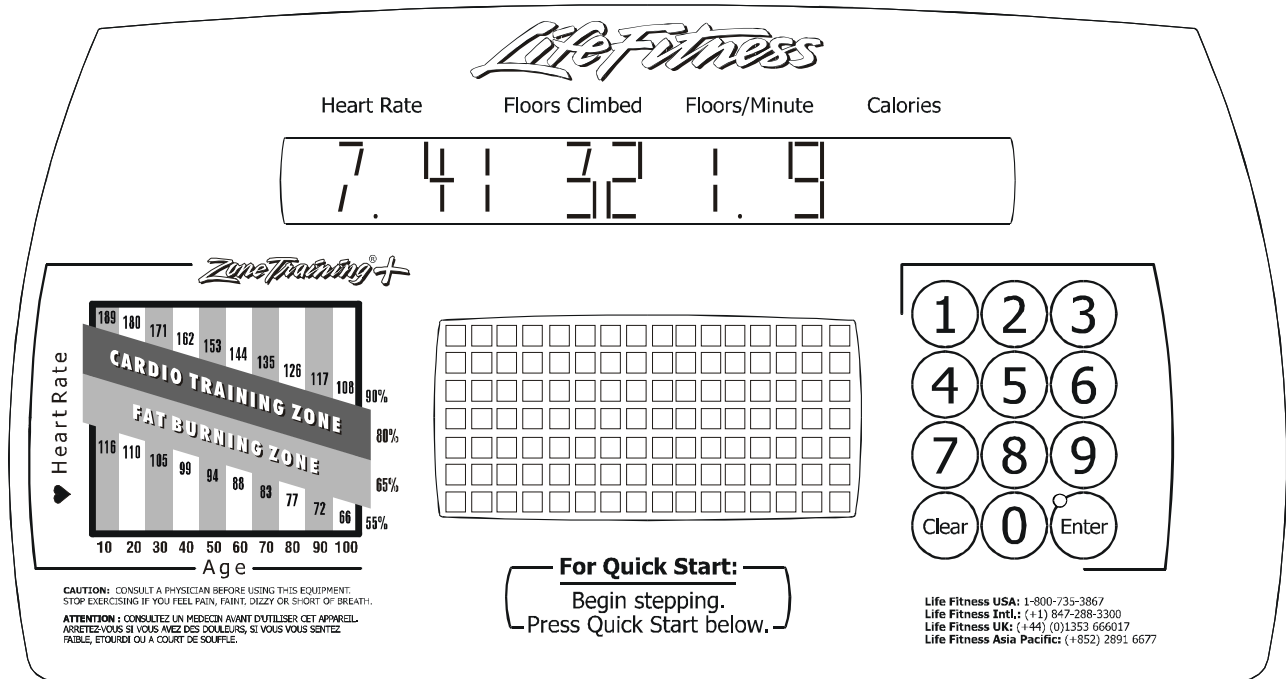

When stepping motion is applied, the system voltage (Vsys) is supplied by the alternator. The value appears in the Heart Rate Window.

When not stepping on the stepper, the alternator is taken out of the system and the battery is the supply voltage. This value is displayed in the Heart Rate Window.

The present Reed Switch RPM is displayed in the Floors Climbed Window. The Reed Switch RPM will not display when the alternator is running.

The present step rate will be displayed in the Floors/Minute Window.

Press the ENTER Key to advance to the next diagnostic state.

Press the CLEAR Key to return to the previous diagnostic state.

Exit the diagnostic state by pressing the CLEAR Key until the display reads SELECT WORKOUT.

Independent Stairclimbers SC95, SC91, SC85, S9i, 95Si, 90S, and 95Se
TEST/SERVICE – SIGNAL INTEGRITY TEST

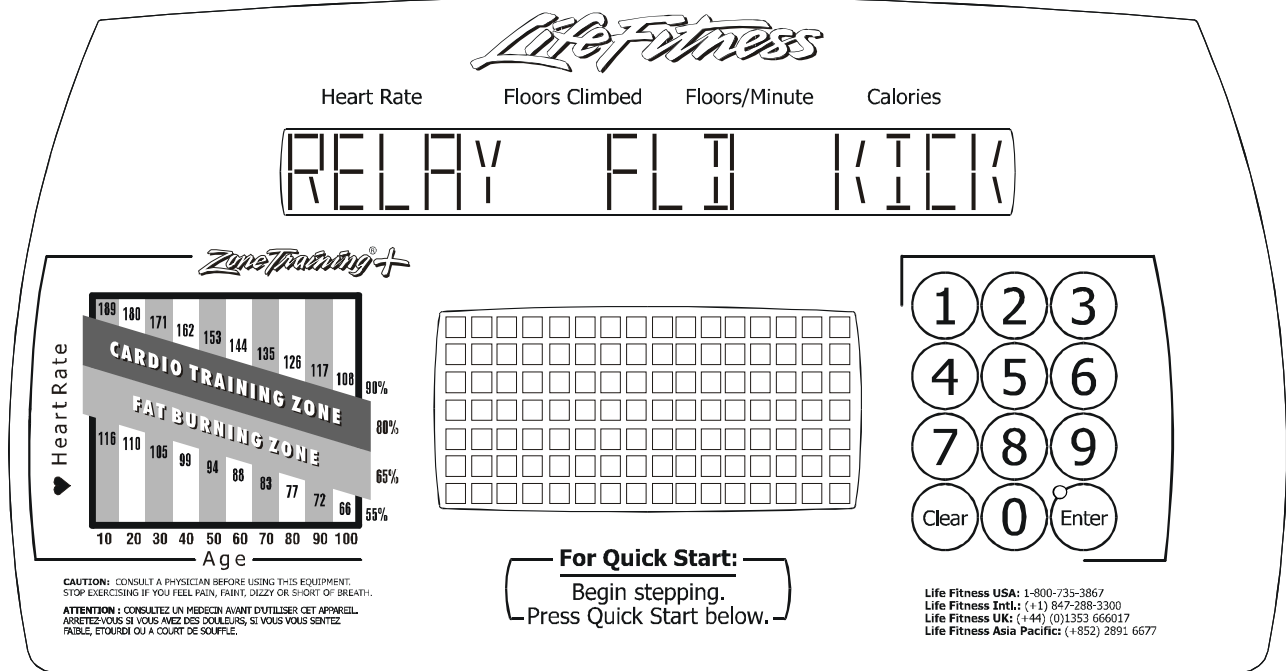

This state does not apply for service usage. It is used by engineering.

- Press the ENTER Key to advance to the next diagnostic state.
- Press the CLEAR Key to return to the previous diagnostic state.
- Exit the diagnostic state by pressing the CLEAR Key until the display reads SELECT WORKOUT.

Independent Stairclimbers SC95, SC91, SC85, S9i, 95Si, 90S, and 95Se
TEST/SERVICE - LIFE PULSE TEST

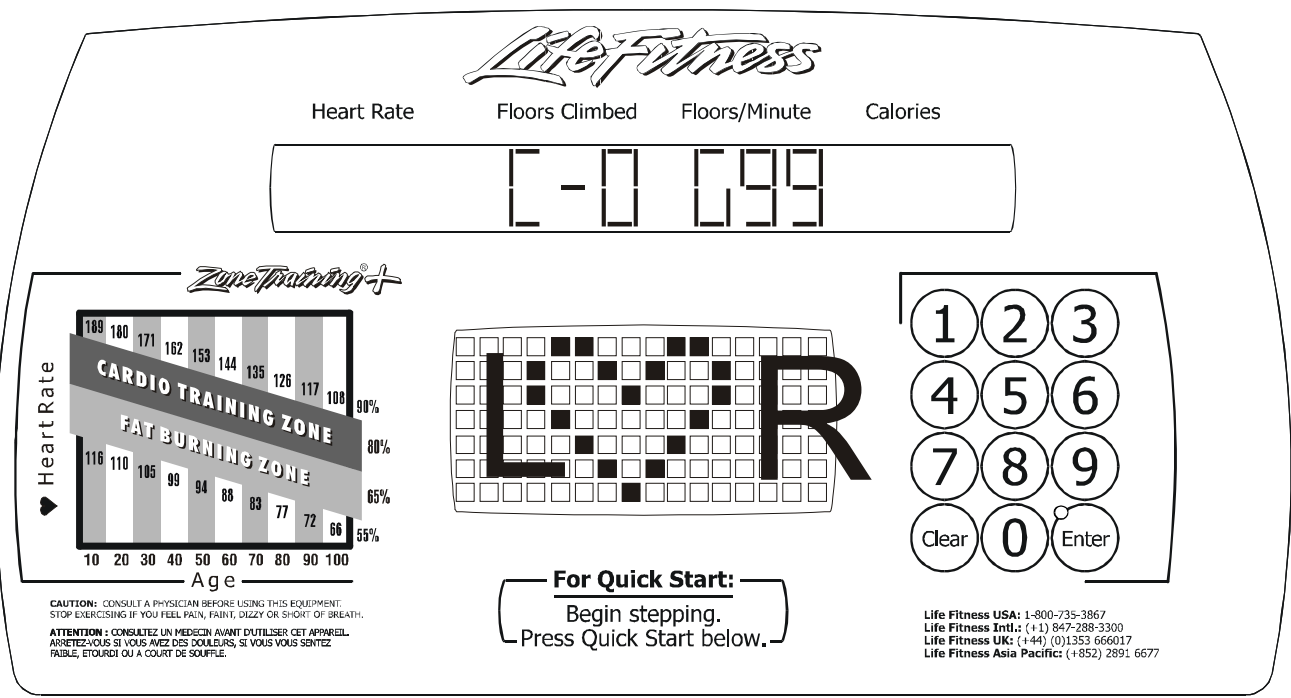

Upon initial entry to this test, a heart-shaped image will be displayed in the profile window along with two messages in the message center when the user has both hands on the lifepulse sensors. The first message indicates the lifepulse software version number. The second is the configuration of the lifepulse communication system, which is either ON or OFF. This setting enables external communications for lifepulse development only and should be left OFF. Following these messages, the display will change to a mode to display diagnostic information as described below, and the lifepulse system will be ready to be manually tested.

When both hands are detected on the sensors, the letters 'L' and 'R' will be displayed in the profile window along with the heart-shaped image. An "L" is displayed when only the left hand is on the sensor, and an "R" will be displayed when only the right hand is on the sensor.

Two timers will begin counting from the time both the left and right hands on condition occurs. The first timer, located on the upper console message center display, will stop counting when lifepulse computes and displays an initial peak detected heart rate reading. The second timer, located on the lower console display window, will continue counting until lifepulse can reliably display the users heart rate. These timer readings are used for reference only.

The gain value of the heart rate signal is shown following the 'G' in the message display window. The value ranges from 0 to 99. A gain value of 99 is considered to be high and undesirable. A gain value of 0 is considered to be low and also undesirable. Gain values of between 15 and 40 are considered normal depending upon whether the user is exercising or standing still during this test.

Press the ENTER Key to advance to the next diagnostic state.
 Press the CLEAR Key to return to the previous diagnostic state.
 Exit the diagnostic state by pressing the CLEAR Key until the display reads SELECT WORKOUT.

**Independent Stairclimbers SC95, SC91, SC85, S9i, 95Si, 90S, and 95Se
TEST/SERVICE - CSAFE NETWORK INTERFACE TEST**

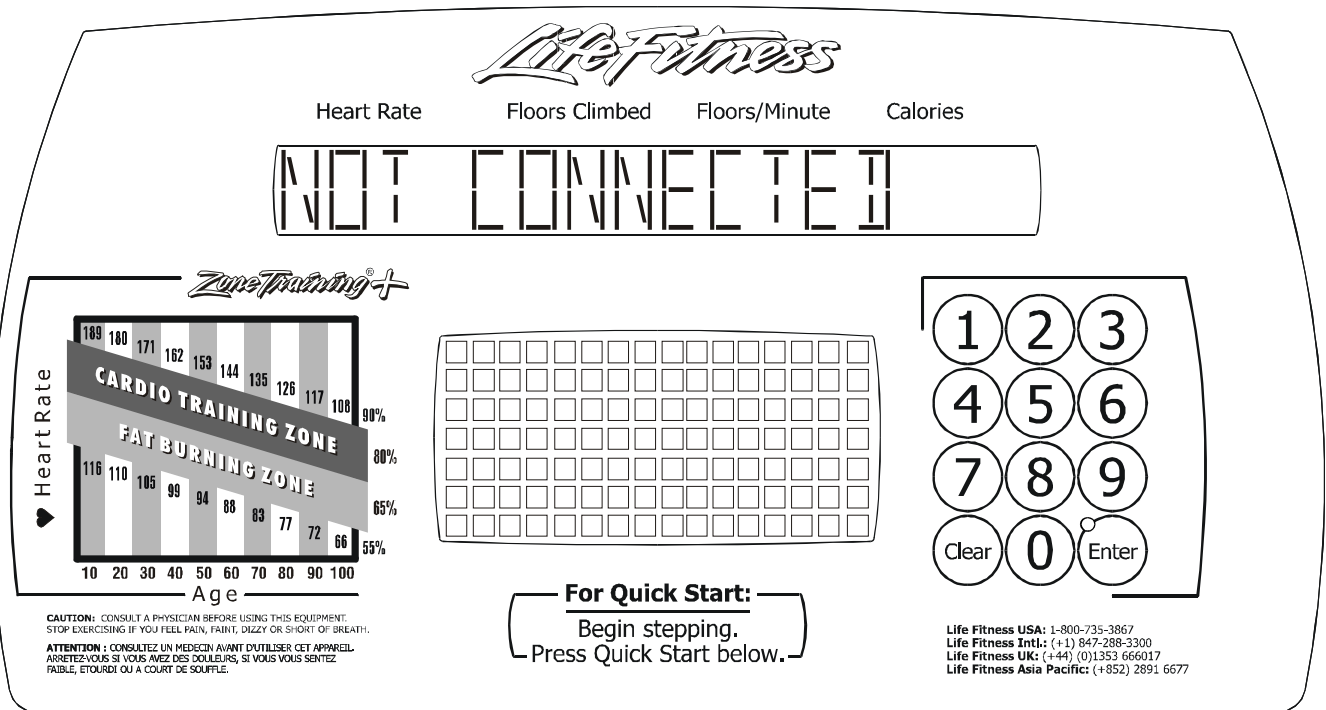

Within this state, the CSAFE network can be tested.

This is how you can check to see if you're receiving any communications from the network system.

- 1) Remain in the CSAFE Test Mode above (by not exiting out of it).
- 2) Make sure the network cable is plugged in.
- 3) Press the COOLDOWN key. This will reset the console and send out the standard power up message to the network. The console should display "RESETTING NETWORK". The power up message sent to the network is the same one the console sends every time it is turned on (or anytime it is used by a user on self-powered products).
- 4) If the network has received the CSAFE communication packet from the console and the network sends configuration communication packet to the console the console will display "RECEIVING..."
- 5) If the console has been properly configured by the network and is allowed to accept user ID's then the console would show "GETID MODE XX". The "GETID" message means were in the get ID mode. This is the mode the network must put the console in, before it will ask the user to enter in their ID's. If the console is not put in this mode then the console will not ask for ID's.
- 6) If the network does not response to the console then the console will display a "NOT CONNECTED" message. This indicates there is a problem with the network cable or network itself. This means the console has not received any valid CSAFE communications from the network.

Press the ENTER Key to advance to the next diagnostic state.

Press the CLEAR Key to return to the previous diagnostic state.

Exit the diagnostic state by pressing the CLEAR Key until the display reads SELECT WORKOUT.

**Independent Stairclimbers SC95, SC91, SC85, S9i, 95Si, 90S, and 95Se
TEST/SERVICE - EEPROM TEST**

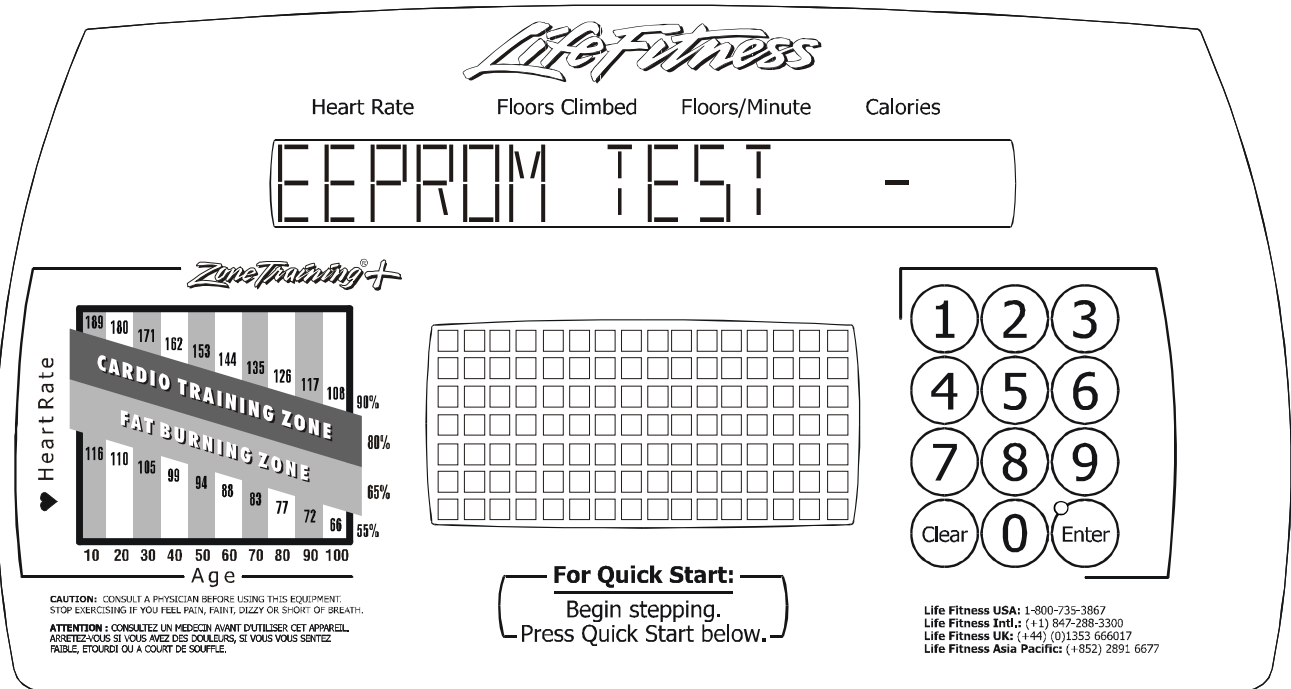

This diagnostic state tests the Display Console EEPROM. The EEPROM location being tested will appear in the display message center. Pressing the DOWN ARROW will initiate the EEPROM test. If the test completes successfully, the message EEPROM GOOD will appear. If the test fails, the message EEPROM BAD AT XX will display with the bad EEPROM location.

- Press the ENTER Key to advance to the next diagnostic state.
- Press the CLEAR Key to return to the previous diagnostic state.
- Exit the diagnostic state by pressing the CLEAR Key until the display reads SELECT WORKOUT.

Independent Stairclimbers SC95, SC91, SC85, S9i, 95Si, 90S, and 95Se
TEST/SERVICE - TELEMETRY ENABLE/DISABLE

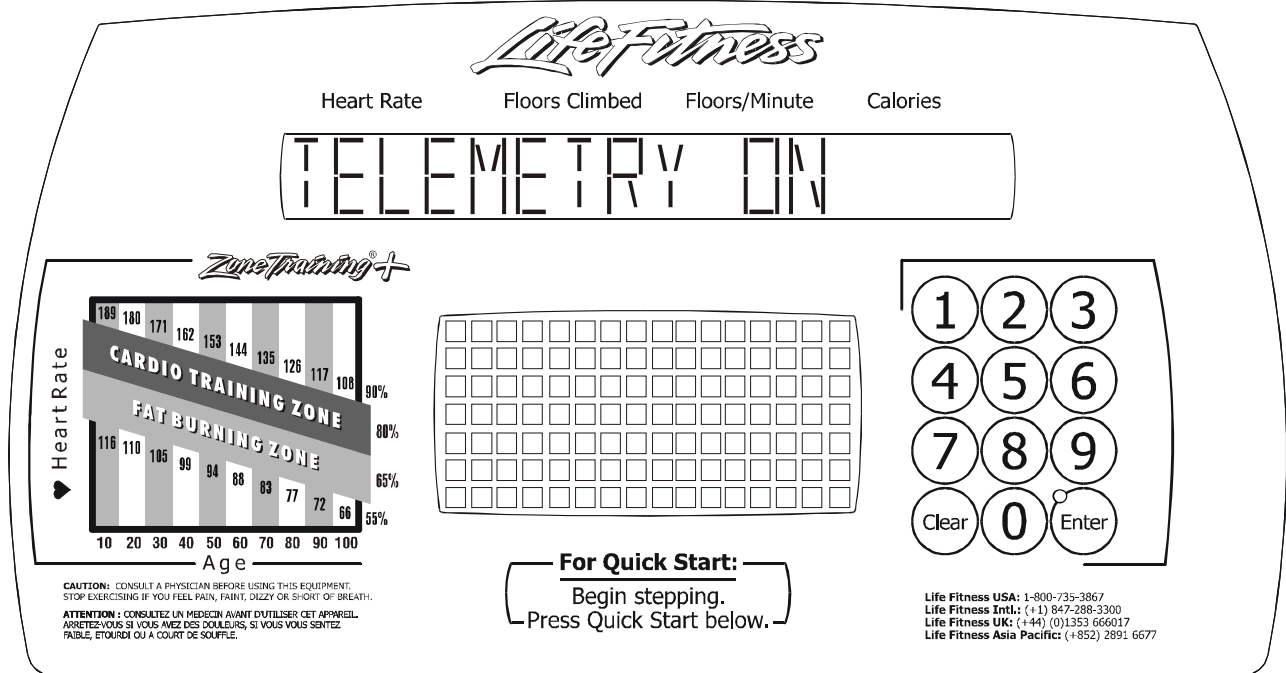

Within this state, the TELEMETRY can be turned ON or OFF. If a telemetry heart rate is detected, it will be displayed when telemetry is set to ON.

By default, the stairclimbers will have TELEMETRY ON.

The DOWN ARROW will turn OFF the telemetry.

The UP ARROW will turn ON the telemetry and display a heart shape in the program profile window.

The ENTER key LED indicates when the value is at the default setting of TELEMETRY ON. This data is stored in EEPROM.

Press the ENTER Key to advance to the next diagnostic state.

Press the CLEAR Key to return to the previous diagnostic state.

Exit the diagnostic state by pressing the CLEAR Key until the display reads SELECT WORKOUT.

Independent Stairclimbers SC95, SC91, SC85, S9i, 95Si, 90S, and 95Se
TEST/SERVICE - LANGUAGE

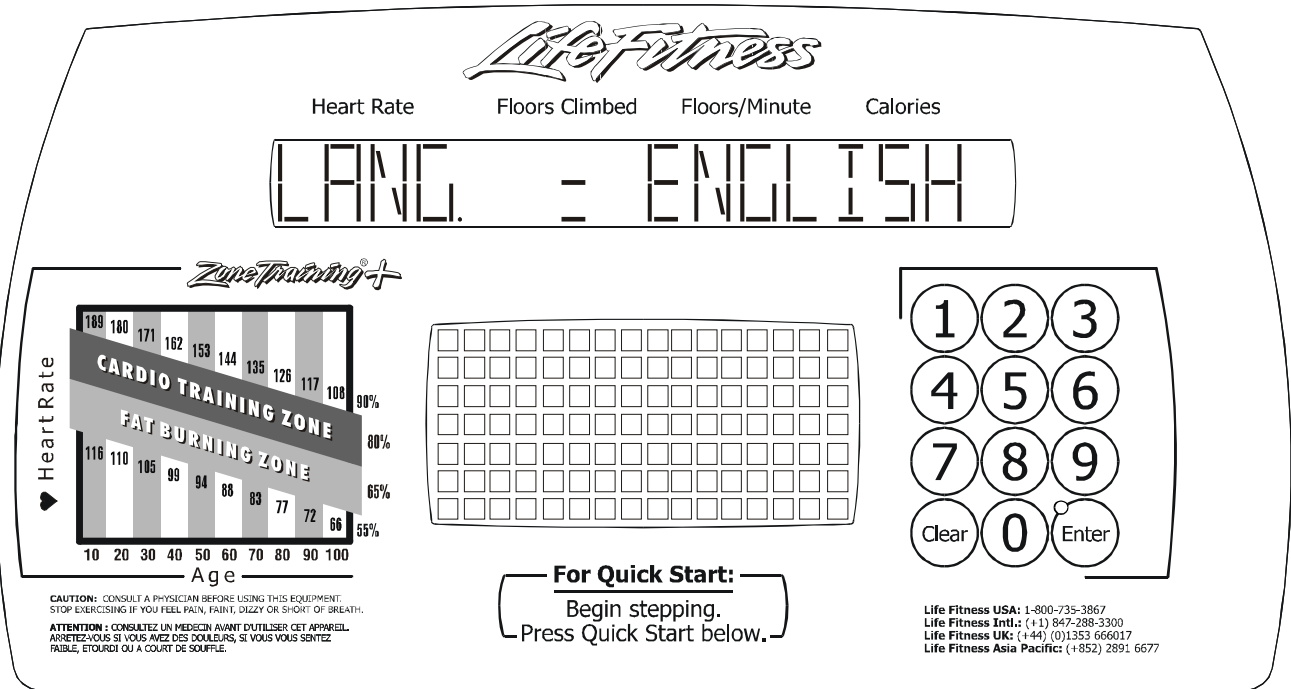

Within this state, one of eight languages can be selected to include English, German, French, Italian, Japanese, Dutch, Spanish or Portuguese.

The UP ARROW, when pressed, displays the next language in the list.

The DOWN ARROW, when pressed, displays the previous language in the list.

The ENTER key LED indicates when the language is set to the default of ENGLISH.

This data is stored in the EEPROM.

Press the ENTER Key to advance to the next diagnostic state.

Press the CLEAR Key to return to the previous diagnostic state.

Exit the diagnostic state by pressing the CLEAR Key until the display reads SELECT WORKOUT.

Independent Stairclimbers SC95, SC91, SC85, S9i, 95Si, 90S, and 95Se
OPTIONAL SETTINGS - MAX PROGRAM DURATION

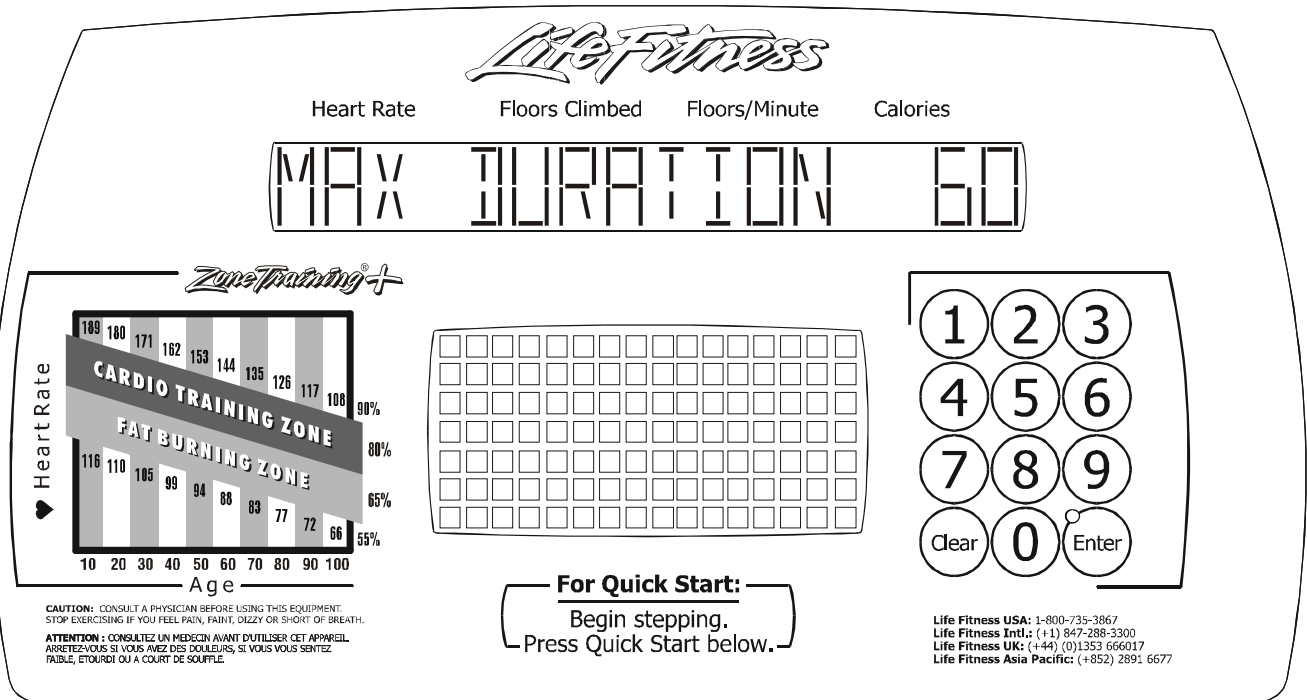

Within this state, the MAXIMUM PROGRAM DURATION is displayed and can be adjusted from a range of 1-99 minutes.

The DOWN ARROW will decrease the value by 1 minute. Key will Auto-Repeat if held.

The UP ARROW will increase the value by 1 minute. Key will Auto-Repeat if held.

The ENTER key LED indicates when the value is at the default of 60 minutes. This data is stored in the EEPROM.

Press the ENTER Key to advance to the next diagnostic state.

Press the CLEAR Key to return to the previous diagnostic state.

Exit the diagnostic state by pressing the CLEAR Key until the display reads SELECT WORKOUT.

Independent Stairclimbers SC95, SC91, SC85, S9i, 95Si, 90S, and 95Se
ENGLISH/METRIC UNIT SELECTION

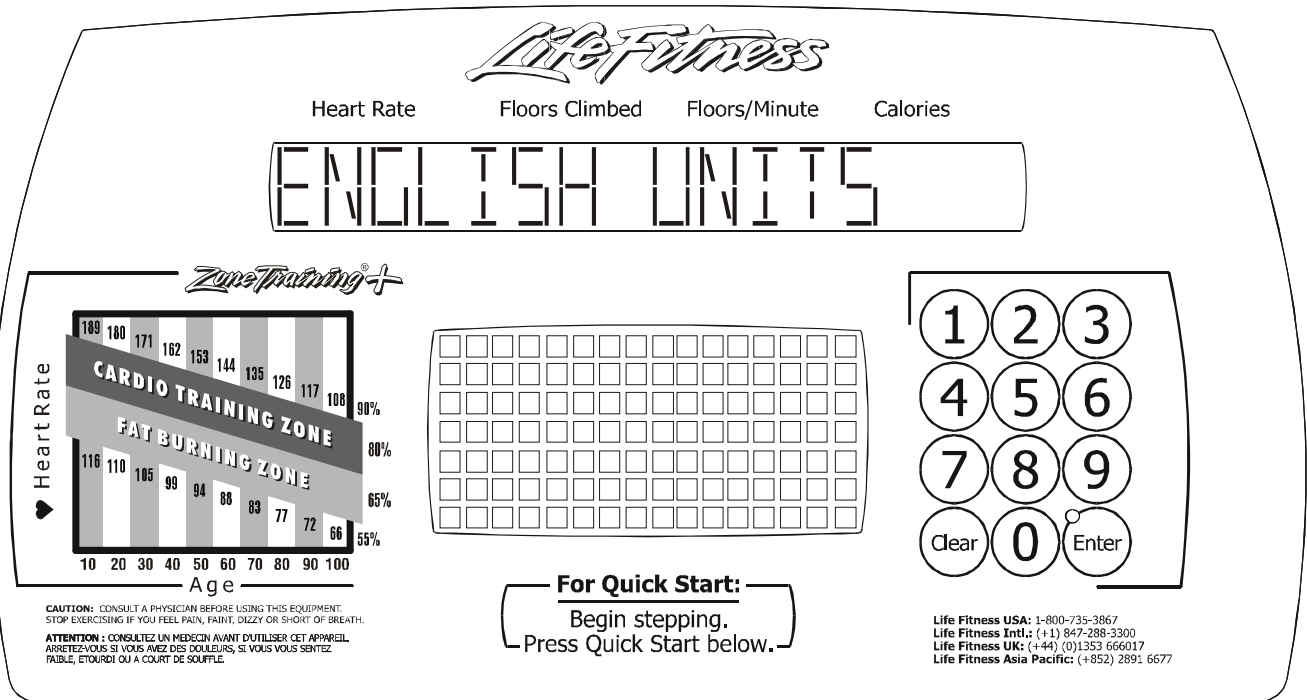

Within this state, ENGLISH or METRIC units can be selected.

The DOWN ARROW will select METRIC units.

The UP ARROW will select ENGLISH units.

The ENTER key LED indicates when the value is at the default setting of ENGLISH UNITS.

This value is stored in EEPROM and is kept when the unit is not in use.

Press the ENTER Key to advance to the next diagnostic state.

Press the CLEAR Key to return to the previous diagnostic state.

Exit the diagnostic state by pressing the CLEAR Key until the display reads SELECT WORKOUT.

Independent Stairclimbers SC95, SC91, SC85, S9i, 95Si, 90S, and 95Se
WATTS DISPLAY ENABLE/DISABLE

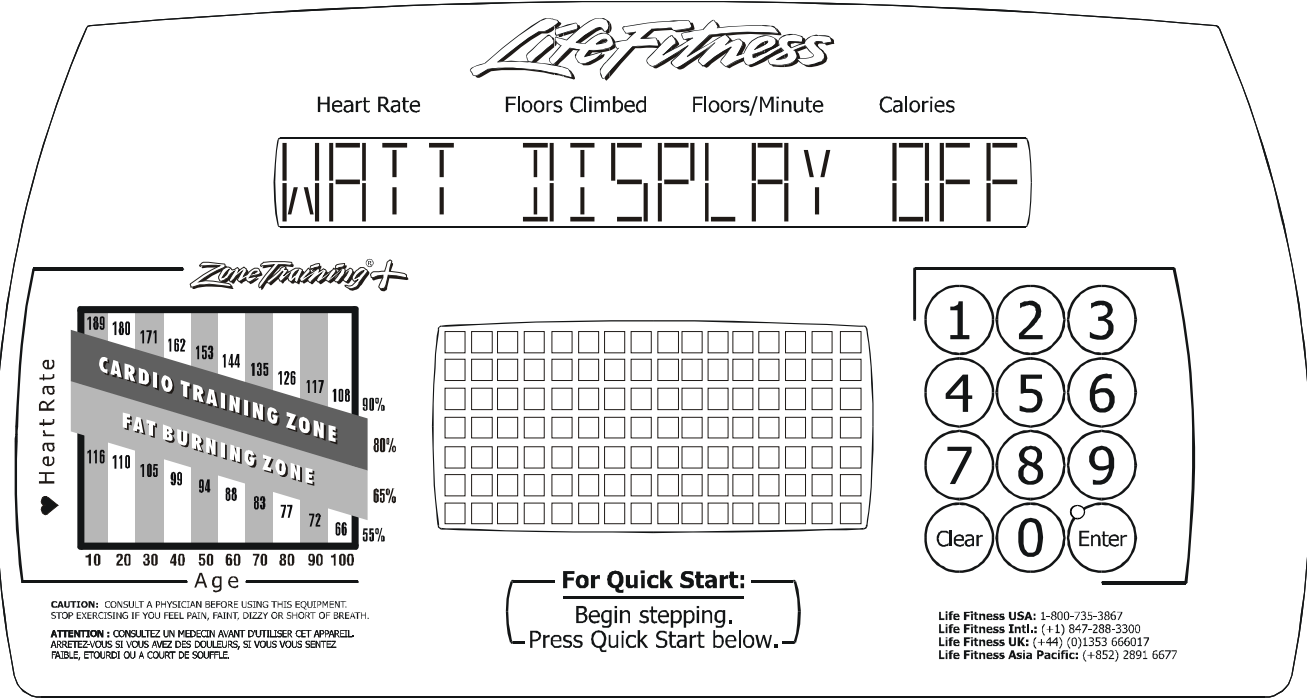

If this option is enabled, the MESSAGE CENTER displays the Watts equivalent of the RPM. This message will only be displayed after a level change.

The DOWN ARROW will turn OFF the WATTS DISPLAY.

The UP ARROW will turn ON the WATTS DISPLAY.

The ENTER key LED indicates when the value is at the default setting of WATTS DISPLAY ON.

The value is stored in EEPROM and is kept when the stepper is not in use.

Press the ENTER Key to advance to the next diagnostic state.

Press the CLEAR Key to return to the previous diagnostic state.

Exit the diagnostic state by pressing the CLEAR Key until the display reads SELECT WORKOUT.

Independent Stairclimbers SC95, SC91, SC85, S9i, 95Si, 90S, and 95Se
METS DISPLAY ENABLE/DISABLE

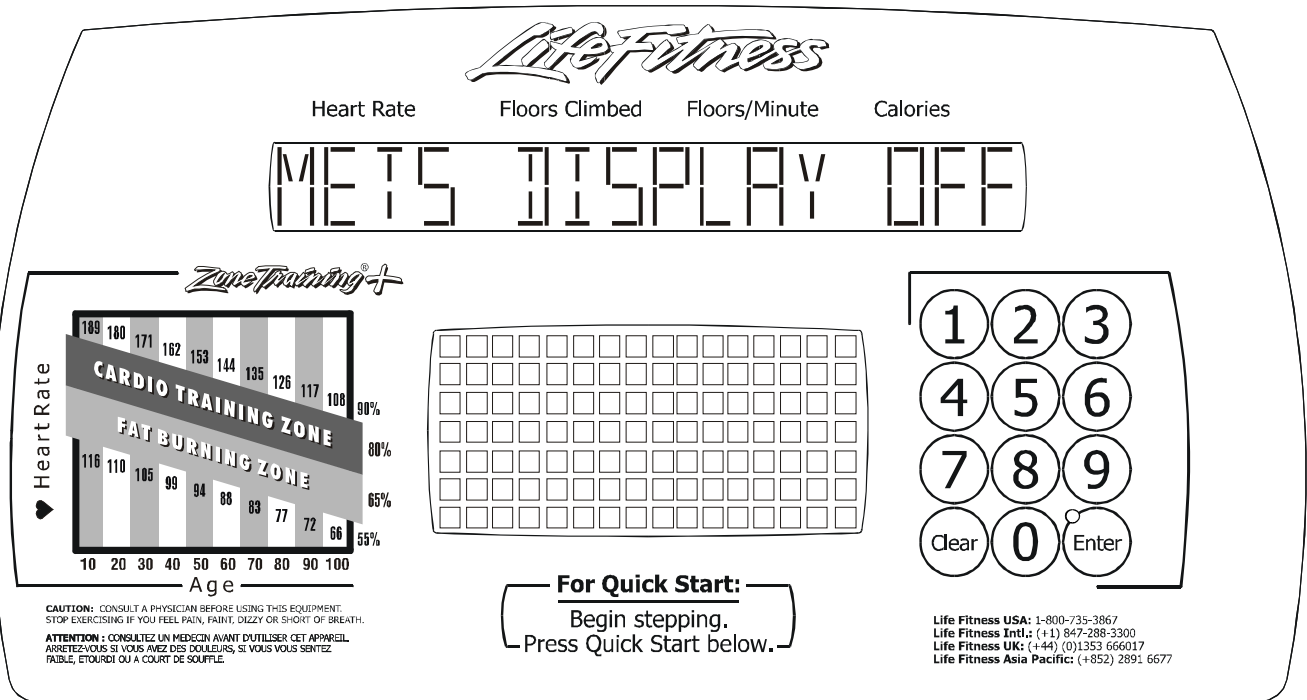

If this option is enabled, the MESSAGE CENTER DISPLAYS the METs equivalent of the RPM. This message will only be displayed after a level change.

The DOWN ARROW will turn OFF the METS DISPLAY.

The UP ARROW will turn ON the METS DISPLAY.

The ENTER key LED indicates when the value is at the default setting of METS DISPLAY OFF.

The value is stored in EEPROM and is kept when the stepper is not in use.

Press the ENTER Key to advance to the next diagnostic state.

Press the CLEAR Key to return to the previous diagnostic state.

Exit the diagnostic state by pressing the CLEAR Key until the display reads SELECT WORKOUT.

Independent Stairclimbers SC95, SC91, SC85, S9i, 95Si, 90S, and 95Se
CAL/HR DISPLAY ENABLE/DISABLE

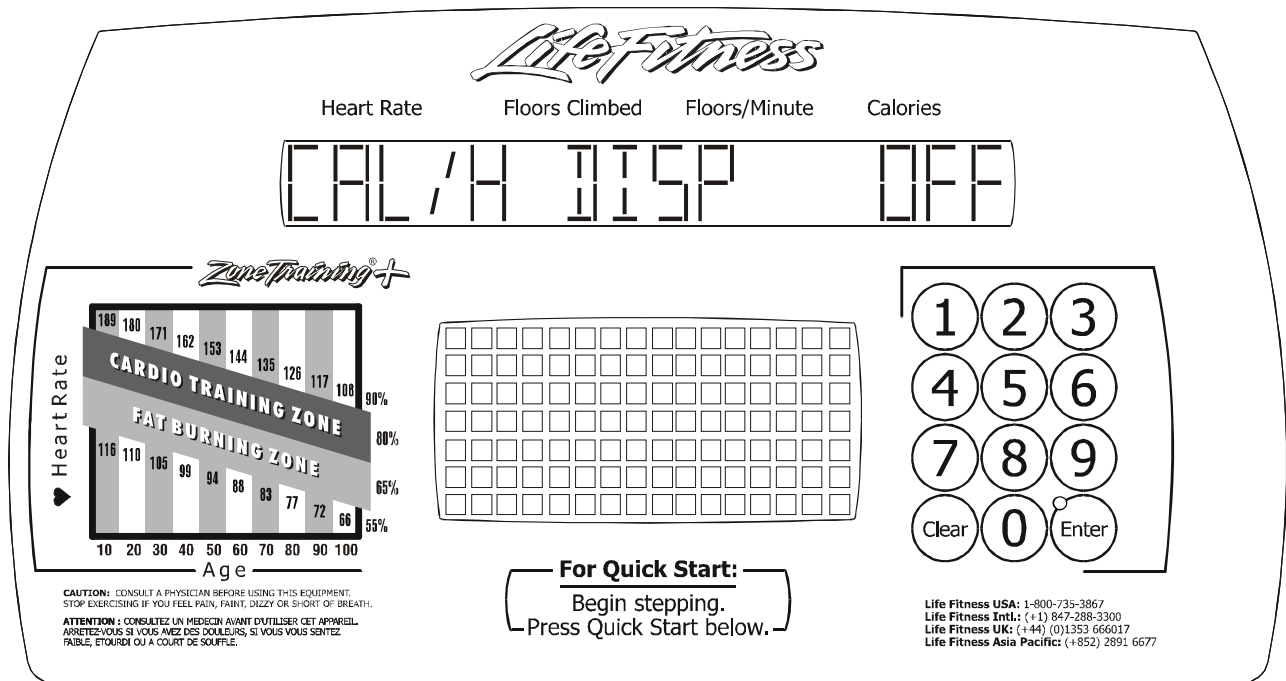

If this option is enabled, the MESSAGE CENTER displays the Calories/Hour equivalent of the RPM. This message will only be displayed after a level change.

The DOWN ARROW will turn OFF the CAL/H program.

The UP ARROW will turn ON the CAL/H program.

The ENTER key LED indicates when the value is at the default setting of CAL/H PROGRAM OFF.

The value is stored in EEPROM and is kept when the stepper is not in use.

Press the ENTER Key to advance to the next diagnostic state.

Press the CLEAR Key to return to the previous diagnostic state.

Exit the diagnostic state by pressing the CLEAR Key until the display reads SELECT WORKOUT.

Independent Stairclimbers SC95, SC91, SC85, S9i, 95Si, 90S, and 95Se
METS PROGRAM ENABLE/DISABLE

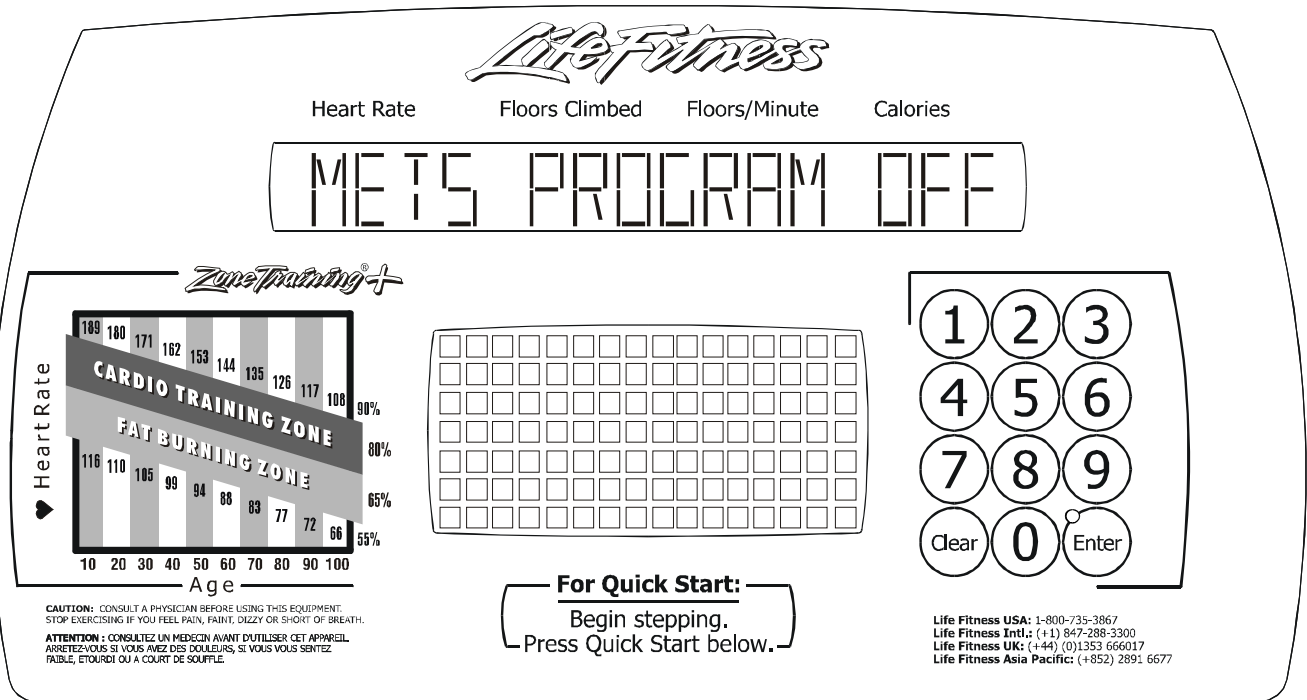

Within this state, METS PROGRAM can be turned ON or OFF.

By default, the Stairclimber will have the METS PROGRAM OFF.

The DOWN ARROW will turn OFF the METS PROGRAM.

The UP ARROW will turn ON the METS PROGRAM.

The ENTER key LED indicates when the value is at the default of METS PROGRAM OFF.

This value is stored in EEPROM and is kept when the stepper is not in use.

Press the ENTER Key to advance to the next diagnostic state.

Press the CLEAR Key to return to the previous diagnostic state.

Exit the diagnostic state by pressing the CLEAR Key until the display reads SELECT WORKOUT.

Independent Stairclimbers SC95, SC91, SC85, S9i, 95Si, 90S, and 95Se
TOTAL HOURS AND STATISTICS

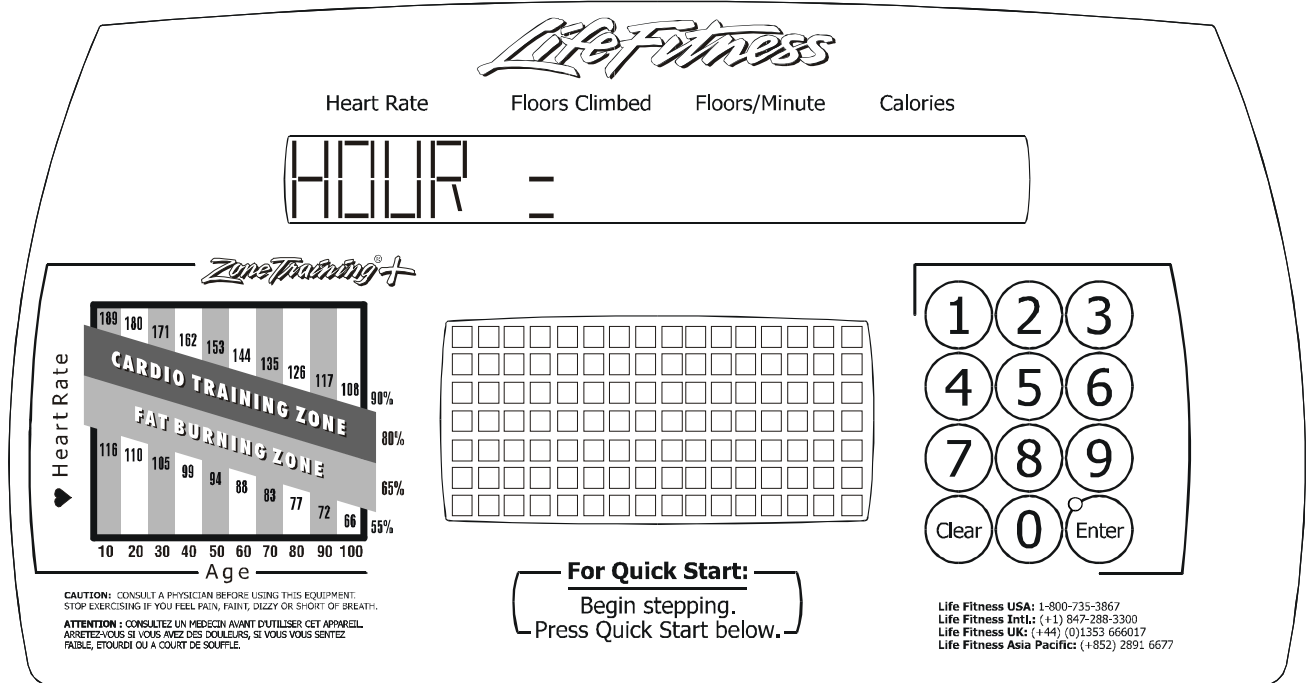

Upon entry to this state, TOTAL HOURS are displayed.

STATISTICS can be displayed using the UP and DOWN arrow keys. The UP ARROW allows scrolling through the available programs and shows the number of times each program has been selected. The DOWN ARROW backs up through the list of available programs and back to the total hours displayed.

The Programs are:

- HOUR = Total hours on the console
- DIST = Total distance in miles on the console
- HILL = Number of times the program is used
- RANDOM = Number of times the program is used
- MANUAL = Number of times the program is used
- FAT = Number of times the program is used
- CARDIO = Number of times the program is used
- AEROBICS = Number of times the program is used
- X-REV = Number of times the program is used
- WATTS = Number of times the program is used
- METS = Number of times the program is used
- QUICK = Number of times the program is used
- HEART HILL = Number of times the program is used
- HEART INT = Number of times the program is used
- HEART EXT = Number of times the program is used
- PRE SET = Number of times the program is used
- CUSTOM = Number of times the program is used

Press the ENTER Key to advance to the next diagnostic state.
Press the CLEAR Key to return to the previous diagnostic state.
Exit the diagnostic state by pressing the CLEAR Key until the display reads SELECT WORKOUT.

Independent Stairclimbers SC95, SC91, SC85, S9i, 95Si, 90S, and 95Se
ENTERTAINMENT CONTROLS ON/OFF (SC9500 AND 95Si ONLY)

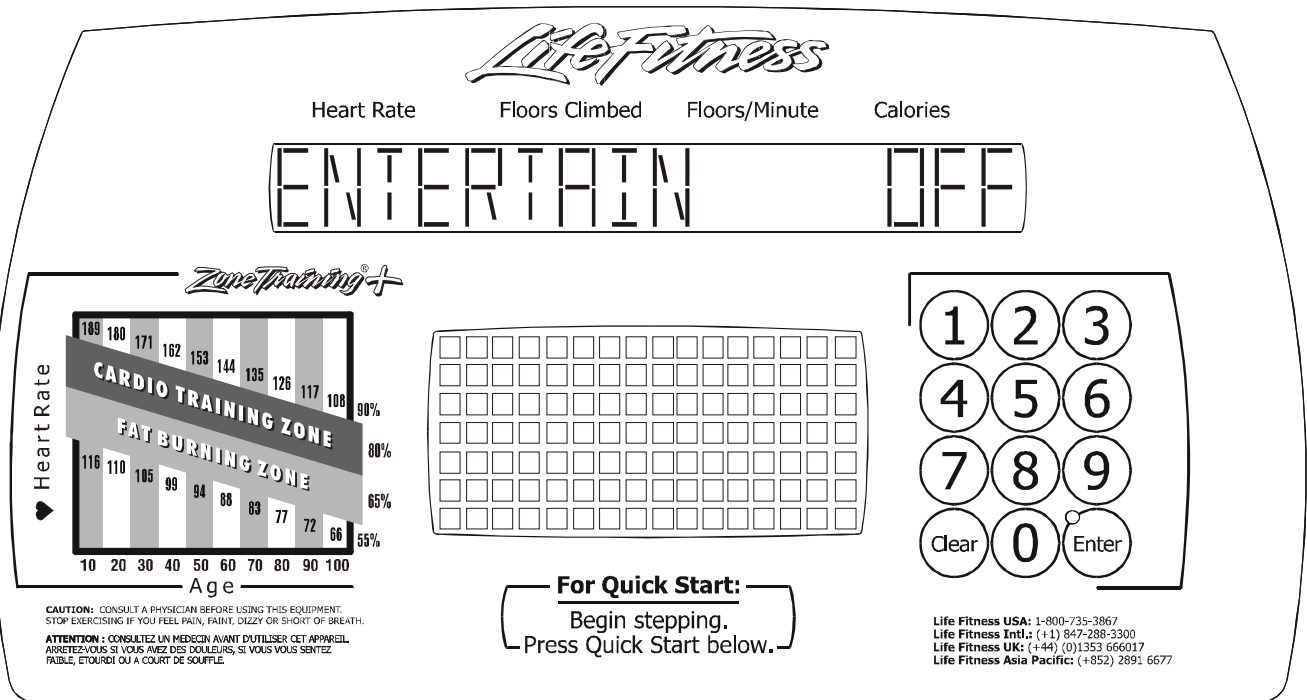

The ENTERTAINMENT CONTROL SETTING

Using the arrow keys will turn ON or OFF the entertainment (cardio theater/broadcast vision). OFF is the default setting for SC9500 only. A separate kit is available for SC9100.

- Press the ENTER Key to advance to the next diagnostic state.
- Press the CLEAR Key to return to the previous diagnostic state.
- Exit the diagnostic state by pressing the CLEAR Key until the display reads SELECT WORKOUT.

Independent Stairclimbers SC95, SC91, SC85, S9i, 95Si, 90S, and 95Se
PHOTO SHOOT (ENABLE/DISABLE)

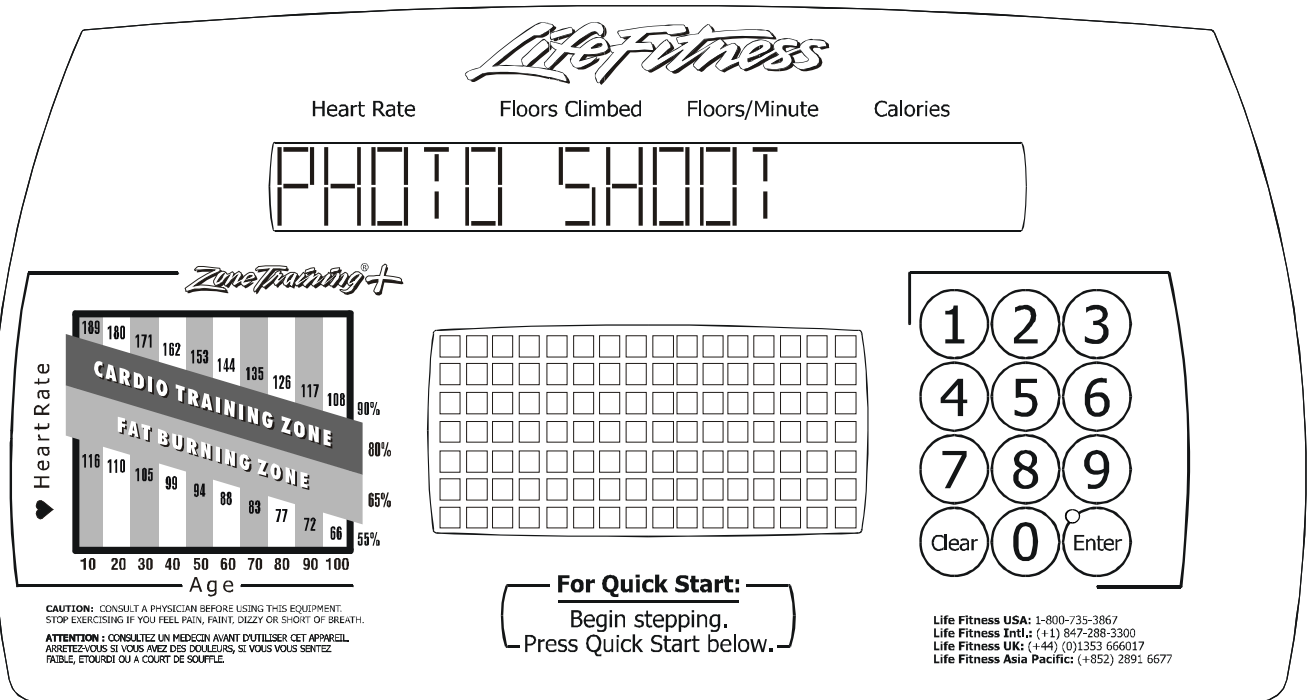

Data displayed in the message center is non-functional and intended only to simulate values for photographic sessions.

Press the CLEAR Key to return to the previous diagnostic state.
 Exit the diagnostic state by pressing the CLEAR Key until the display reads SELECT WORKOUT.

Independent Stairclimbers SC95, SC91, SC85, S9i, 95Si, 90S, and 95Se

Notes

SECTION IIB

DIAGNOSTIC MODES

FOR

95Se LCD UNIT ONLY

Welcome Screen.....	3
Workout Screen	4
Main Menu	5
System Test Menu	6
System Diagnostics.....	7
Test Engineering	8
Telemetry Test	9
LifePulse Test	10
CSAFE Network Test	11
EEPROM Test	12
Information Menu	13
Information Statistics	14
Software Versions	15
System Errors	16
Usage Log Report	17
Configuration Menu	18
Managers Configuration	19
Custom Message Setup	20
Manufacturers Configuration	21
TV Set Up	22
Max Volume Setup	23
Touch Screen Configuration.....	24

Independent Stairclimbers SC95, SC91, SC85, SC9i, 95Si, 93Si, 90S, and 95Se

Notes

Independent Stairclimbers SC95, SC91, SC85, SC9i, 95Si, 93Si, 90S, and 95Se DISPLAY CONSOLE 95Ce LCD ONLY

WELCOME SCREEN



LCD Console Welcome Screen

The Welcome Screen initially appears after Power-Up or when the bike is not in use. Touching the Screen will change the screen to the WORKOUT SELECTION screen.

**Independent Stairclimbers SC95, SC91, SC85, SC9i, 95Si, 93Si, 90S, and 95Se
DISPLAY CONSOLE 95Ce LCD**

WORKOUT SELECTION SCREEN

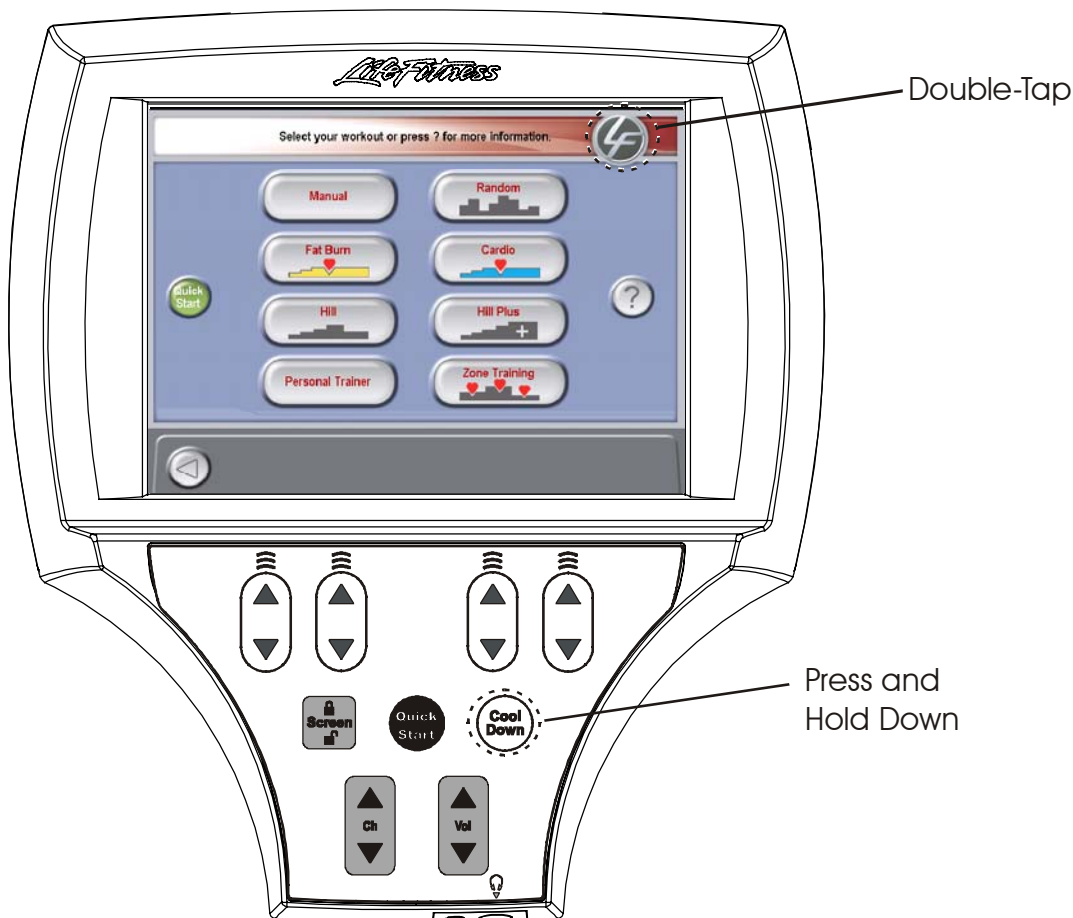

From the Workout Selection Screen you will be able to enter the Systems Option Menu. To enter, go to the Workout Selection Screen then press and hold the COOLDOWN key, and then double-touch the Life Fitness icon.

After entering the System Options the Main Menu will appear. For further information about the programs on this screen, refer to the Operators Manual.

**Independent Stairclimbers SC95, SC91, SC85, SC9i, 95Si, 93Si, 90S, and 95Se
DISPLAY CONSOLE 95Ce LCD**

SYSTEM OPTIONS – MAIN MENU

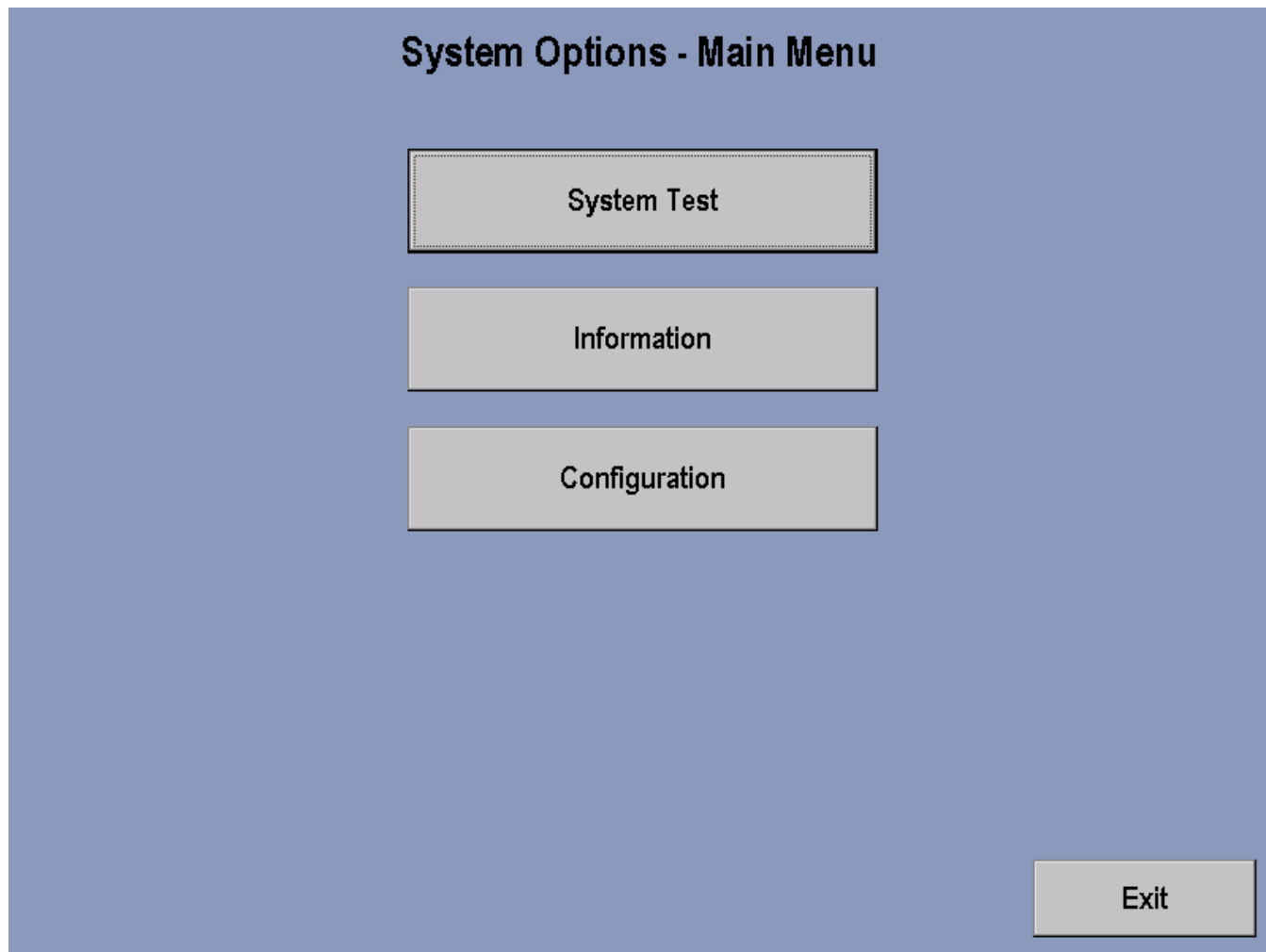

The System Options - Main Menu selections, when pressed, allows access to the System Test Menu, Information Menu, and Configuration Menu.

Pressing the screen Exit key will return you back to the Workout Selection Screen.

**Independent Stairclimbers SC95, SC91, SC85, SC9i, 95Si, 93Si, 90S, and 95Se
DISPLAY CONSOLE 95Ce LCD**

SYSTEM TEST MENU

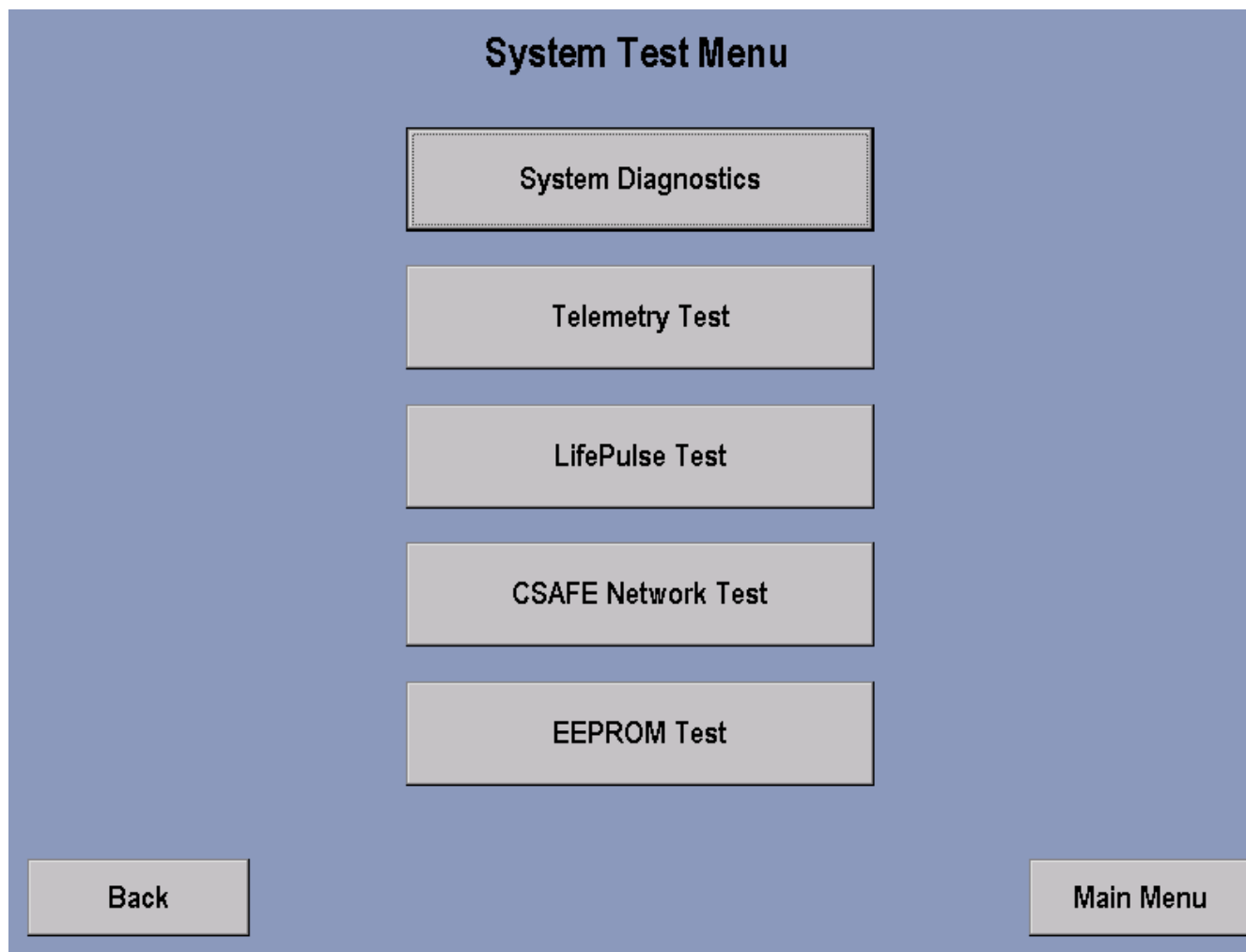

The System Test Menu allows the user to access the above by pressing the appropriate key.

Pressing the screen Back key will return you to the System Options – Main Menu screen.

**Independent Stairclimbers SC95, SC91, SC85, SC9i, 95Si, 93Si, 90S, and 95Se
DISPLAY CONSOLE 95Ce LCD**

SYSTEM DIAGNOSTICS

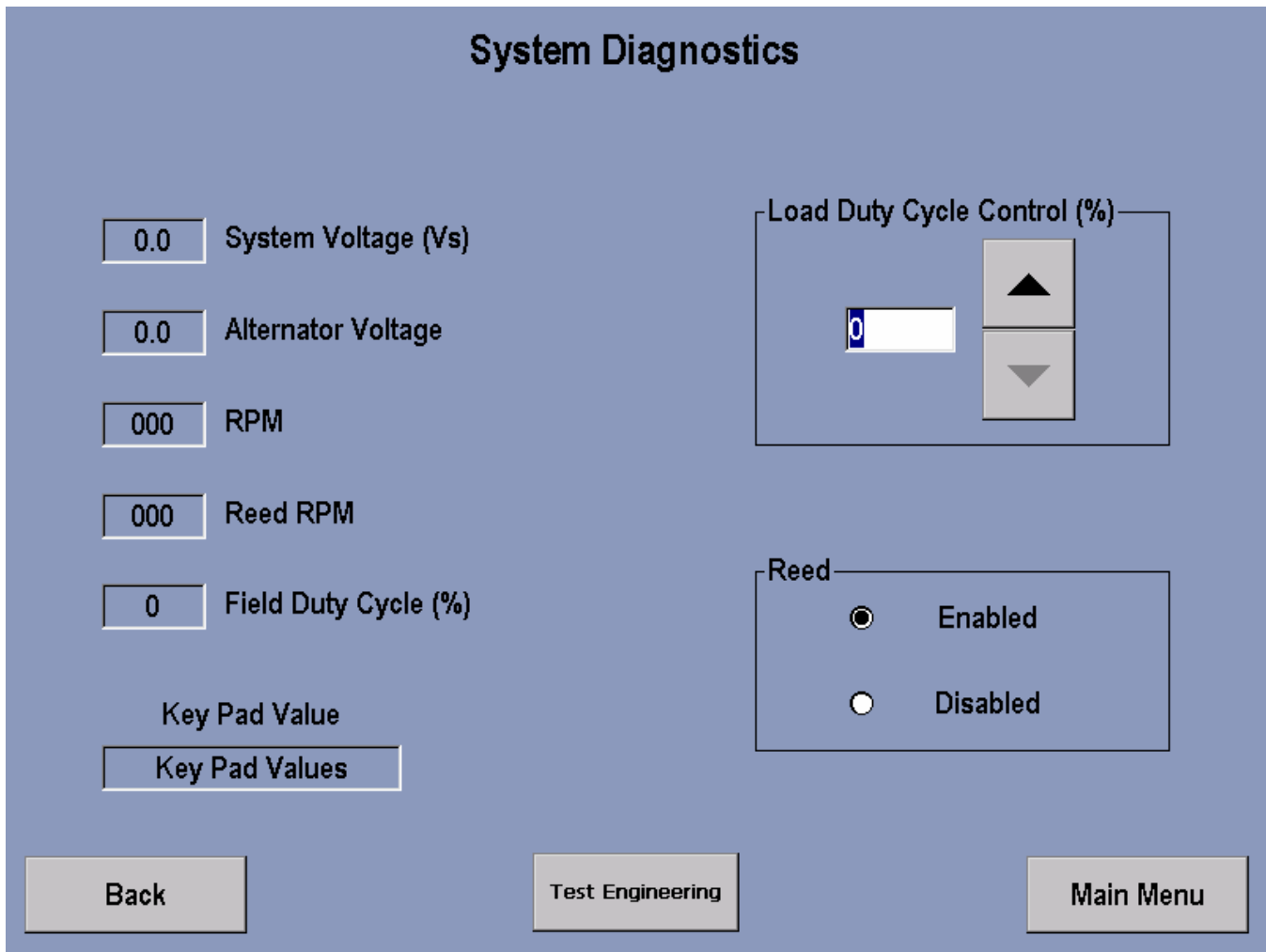

In the SYSTEM DIAGNOSTICS screen the feedback from various sources can be read.

SYSTEM VOLTAGE	Displays the voltage present at the console.
ALTERNATOR VOLTAGE	Displays the voltage out of the Alternator.
RPM	Displays the Crank arm RPM from the Alternator
REED RPM	Displays the Crank arm RPM from the Reed Switch
FIELD DUTY CYCLE	Will display the percentage that the alternator is being activated to produce a load. The Higher the number the harder it is to Pedal.
KEY PAD VALUE	Displays an acknowledgment when a key is pressed on the console
REED	When lit, the circles in the Reed Box indicate that the Reed Switch is Enabled or Disabled. The setting can be toggled by pressing corresponding circle.
TEST ENGINEERING	This test is for engineering purposes and is not applicable to servicing.

Pressing the screen Back button will return you to previous screen. Pressing the screen MAIN MENU key will return you back to the MAIN MENU.

**Independent Stairclimbers SC95, SC91, SC85, SC9i, 95Si, 93Si, 90S, and 95Se
DISPLAY CONSOLE 95Ce LCD**

TEST ENGINEERING

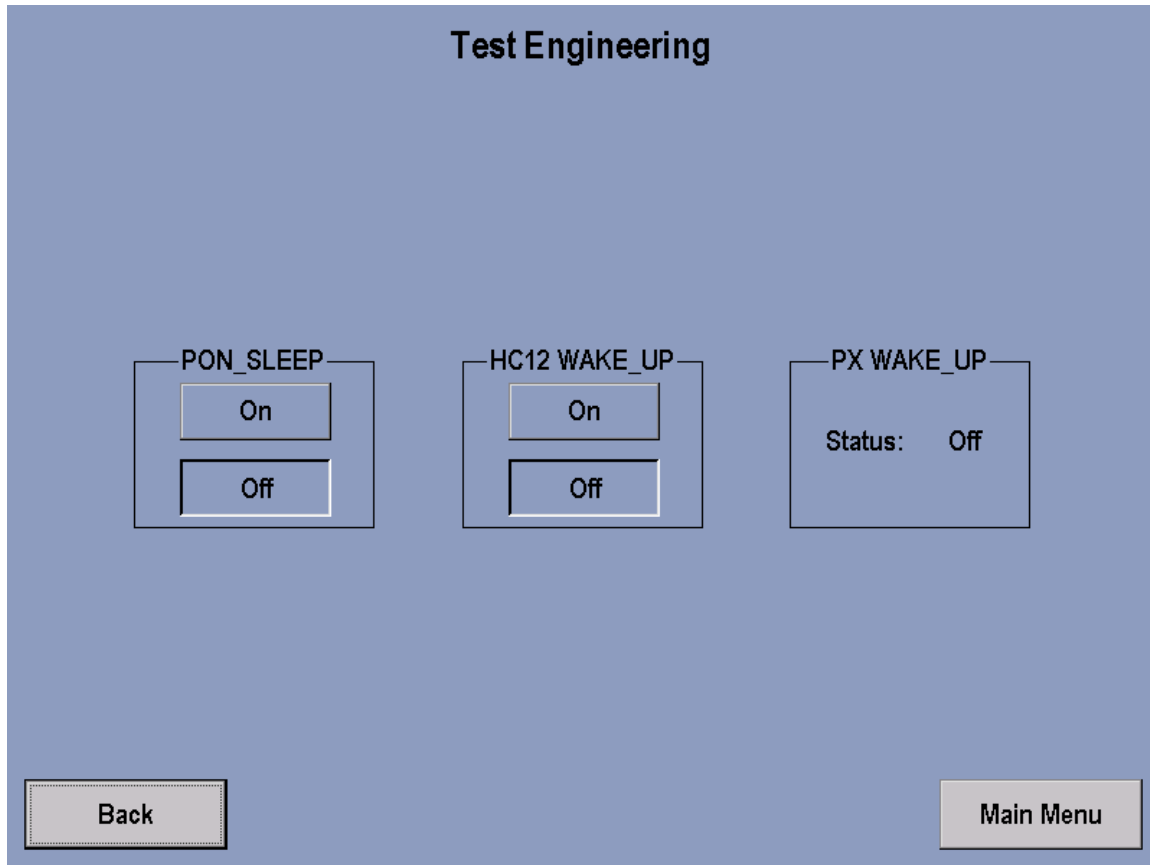

All status windows on this screen should display OFF and should not be changed unless instructed to do so by Life Fitness Customer Support.

Pressing the screen Back key will return you to the System Diagnostics screen.

**Independent Stairclimbers SC95, SC91, SC85, SC9i, 95Si, 93Si, 90S, and 95Se
DISPLAY CONSOLE 95Ce LCD**

TELEMETRY TEST

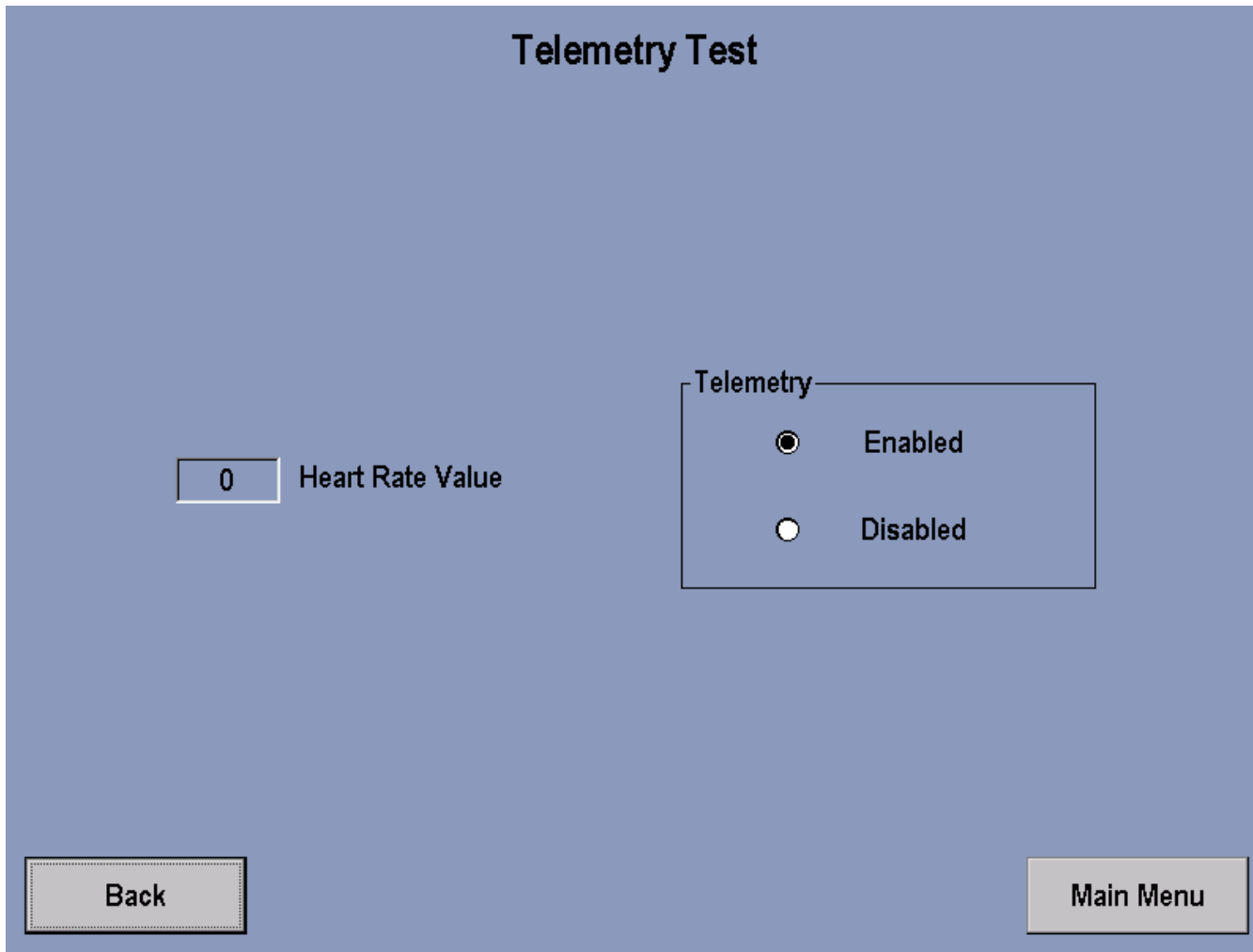

The circles in the Telemetry Box indicate whether Telemetry is Enabled or Disabled. Touching the appropriate circle can enable or disable Telemetry. The Heart rate value window will display the users Heart Rate when Telemetry is enabled.

Pressing the screen Back key will return you to the previous screen. Pressing screen MAIN MENU key will return you back to the MAIN MENU.

Independent Stairclimbers SC95, SC91, SC85, SC9i, 95Si, 93Si, 90S, and 95Se DISPLAY CONSOLE 95Ce LCD

LIFE PULSE TEST

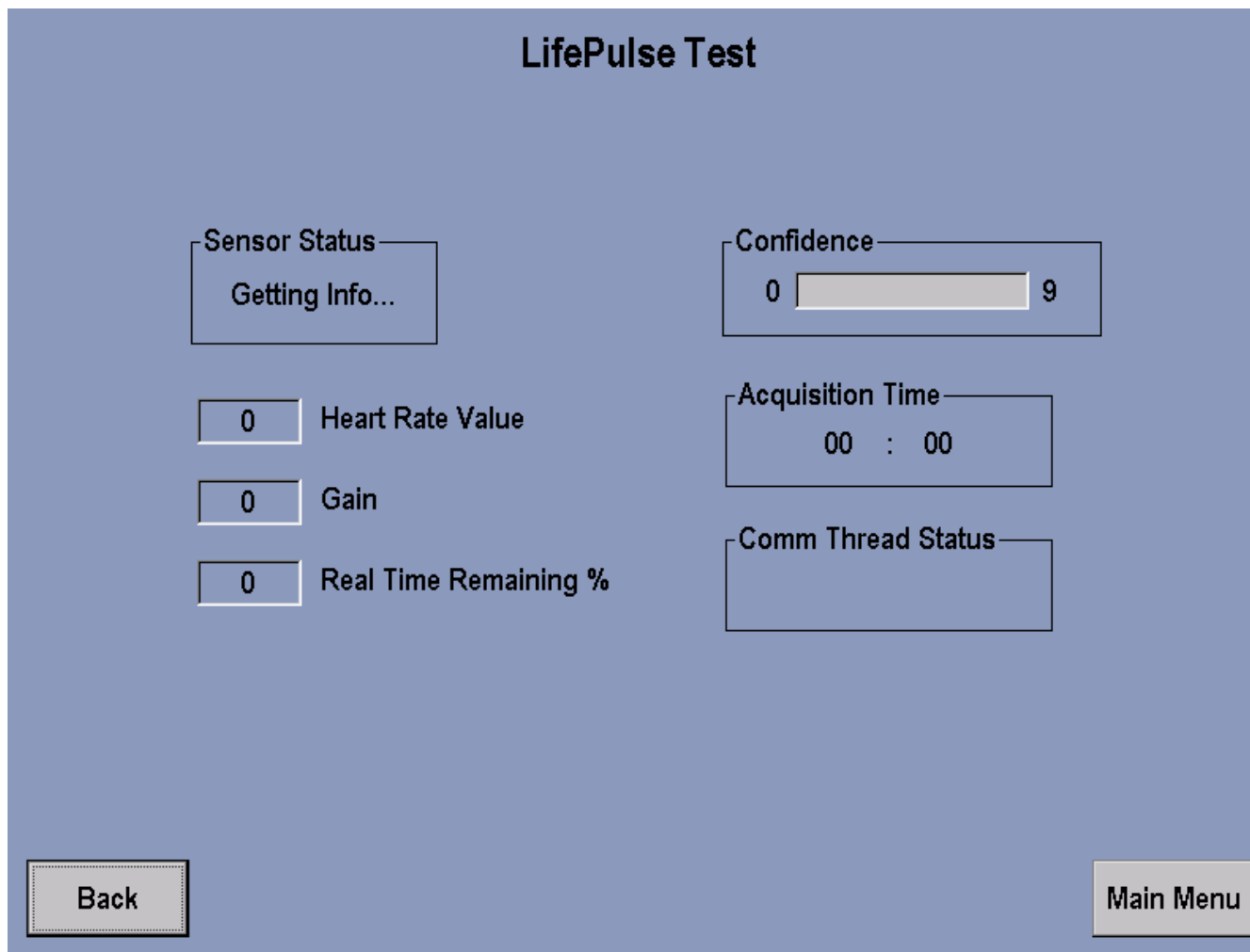

The Lifepulse™ System can be tested manually. The system will display a “Hands-On” reading when the user has placed their hands on the Lifepulse™ Sensors.

A timer will commence (and will show in the Acquisition Time window) from the time both Hands-On condition occurs to when the LifePulse system can generate a heart rate reading. The timer will stop when a numeric heart rate reading appears in the Heart Rate Value window.

The Gain value and Confidence Level will also be displayed in their appropriate windows. Gain indicates the strength of the heart rate signal being received. A low number indicates a strong signal where as a high number indicates a weak signal. The value ranges for confidence go from 0 to 9, with 0 having the lowest confidence value.

Pressing the screen Back key will return you to the previous screen. Pressing the screen Main Menu key will return you to Main Menu.

Independent Stairclimbers SC95, SC91, SC85, SC9i, 95Si, 93Si, 90S, and 95Se
DISPLAY CONSOLE 95Ce LCD

CSAFE TEST

CSafe Test - Not Available at This Time.

**Independent Stairclimbers SC95, SC91, SC85, SC9i, 95Si, 93Si, 90S, and 95Se
DISPLAY CONSOLE 95Ce LCD**

EEPROM TEST

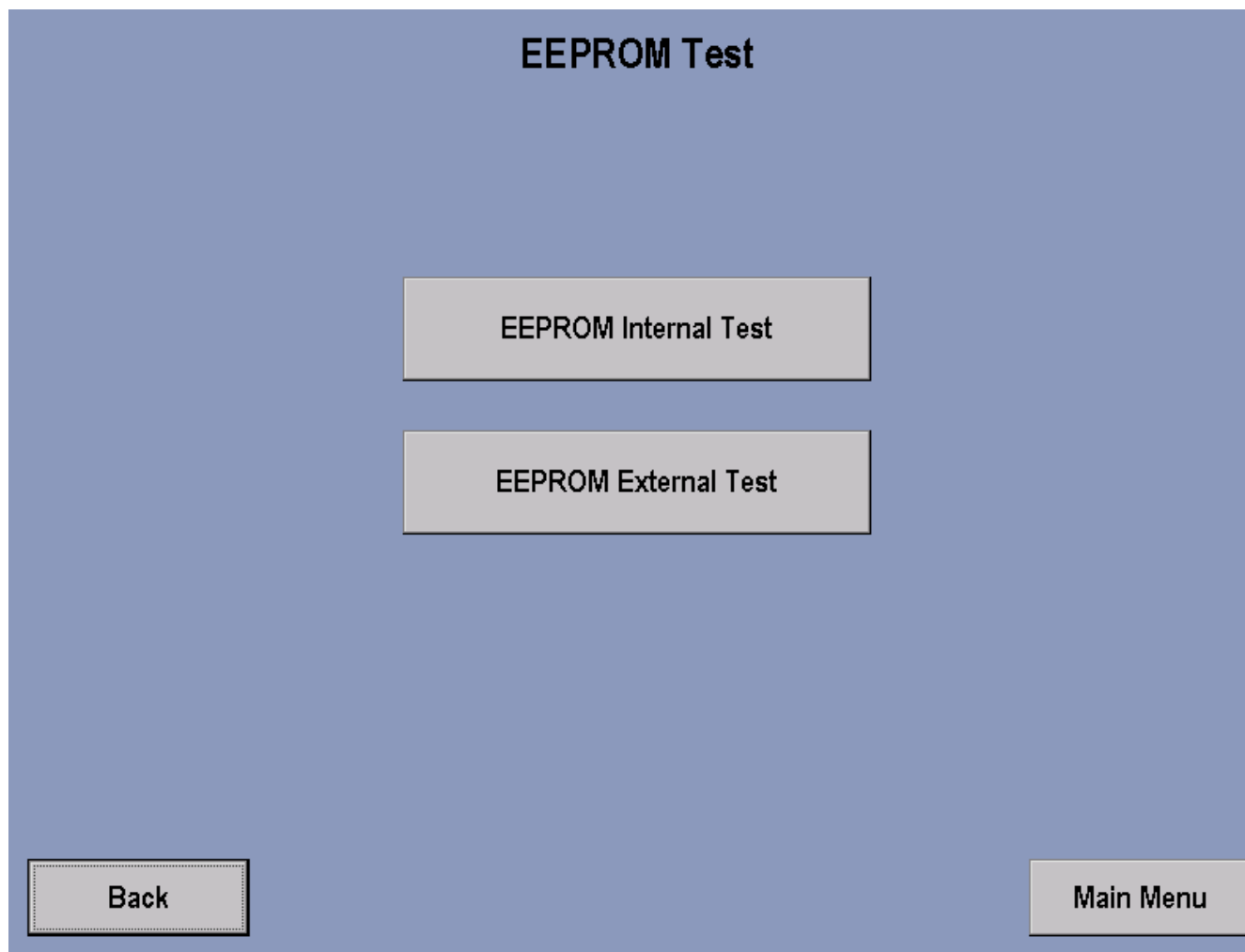

Pressing the screen EEPROM Internal Test key allows testing of the EEPROM on the Single Board Computer.

Pressing the screen EEPROM External Test key allows testing of the EEPROM on the Interface Board.

In either instance, a PASS message will appear if the EEPROM is good

Pressing the screen Back button will return you to previous screen. Pressing the screen MAIN MENU key will return you back to the MAIN MENU.

**Independent Stairclimbers SC95, SC91, SC85, SC9i, 95Si, 93Si, 90S, and 95Se
DISPLAY CONSOLE 95Ce LCD**

INFORMATION MENU

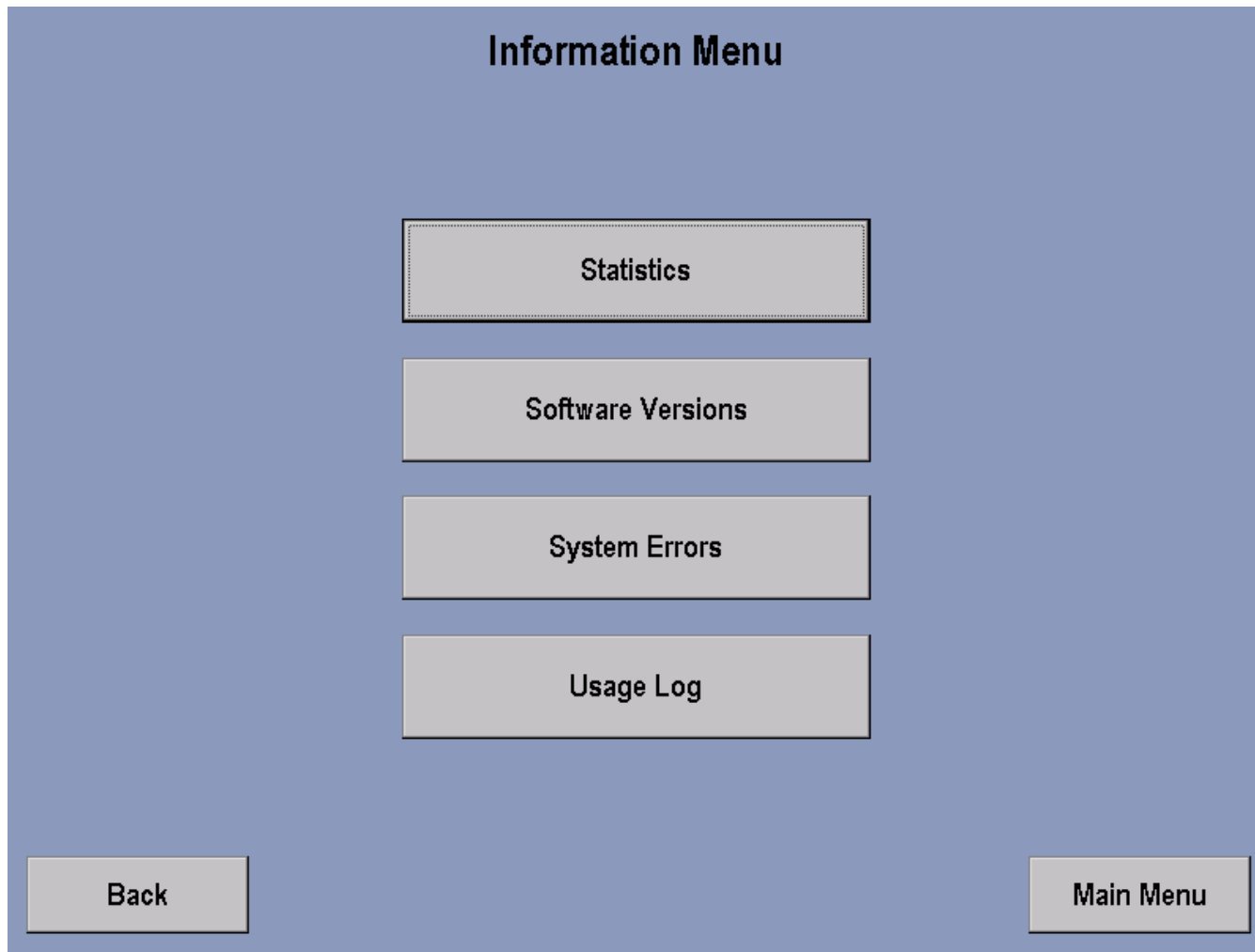

STATISTICS	Displays various historical data regarding individual workout program usage and critical system power levels.
SOFTWARE VERSIONS	Displays current software version information.
SYSTEM ERRORS	Displays historical information regarding system errors encountered during operation.
USAGE LOG	Displays historical information regarding pedal speeds and user weights.

Pressing the screen Back key will return you to System Options – Main Menu screen. Pressing the screen MAIN MENU key will return you back to the MAIN MENU.

**Independent Stairclimbers SC95, SC91, SC85, SC9i, 95Si, 93Si, 90S, and 95Se
DISPLAY CONSOLE 95Ce LCD**

INFORMATION STATISTICS

Information Statistics

TOTAL HOURS:	<input type="text" value="0:00"/>	SPORT TRAINING:	<input type="text" value="0"/>
HILL:	<input type="text" value="0"/>	REVERSE:	<input type="text" value="0"/>
RANDOM:	<input type="text" value="58880"/>	AEROBICS:	<input type="text" value="0"/>
MANUAL:	<input type="text" value="0"/>	EZ RESISTENCE:	<input type="text" value="0"/>
FAT BURN:	<input type="text" value="0"/>	PERSONAL TRAINER:	<input type="text" value="0"/>
CARDIO:	<input type="text" value="0"/>	PRESET:	<input type="text" value="0"/>
QUICK:	<input type="text" value="0"/>	TOTAL DISTANCE:	<input type="text" value="0"/>
WATTS:	<input type="text" value="0"/>	CHARGING TIME:	<input type="text" value="655960"/>
METS:	<input type="text" value="0"/>	DISCHARGING TIME:	<input type="text" value="240"/>
HR HILL:	<input type="text" value="0"/>	MINIMUM VOLTAGE:	<input type="text" value="0.00"/>
HR INTERVAL:	<input type="text" value="0"/>	MAXIMUM VOLTAGE:	<input type="text" value="0.00"/>
EXTREME HR:	<input type="text" value="0"/>		

Entry to this screen allows to user to view statistics such as: total hours of use on the unit and hours of use per program used along with other information.

Pressing the screen Back key will return you to System Options – Main Menu screen. Pressing the screen MAIN MENU key will return you back to the MAIN MENU.

Independent Stairclimbers SC95, SC91, SC85, SC9i, 95Si, 93Si, 90S, and 95Se DISPLAY CONSOLE 95Ce LCD

SOFTWARE VERSION

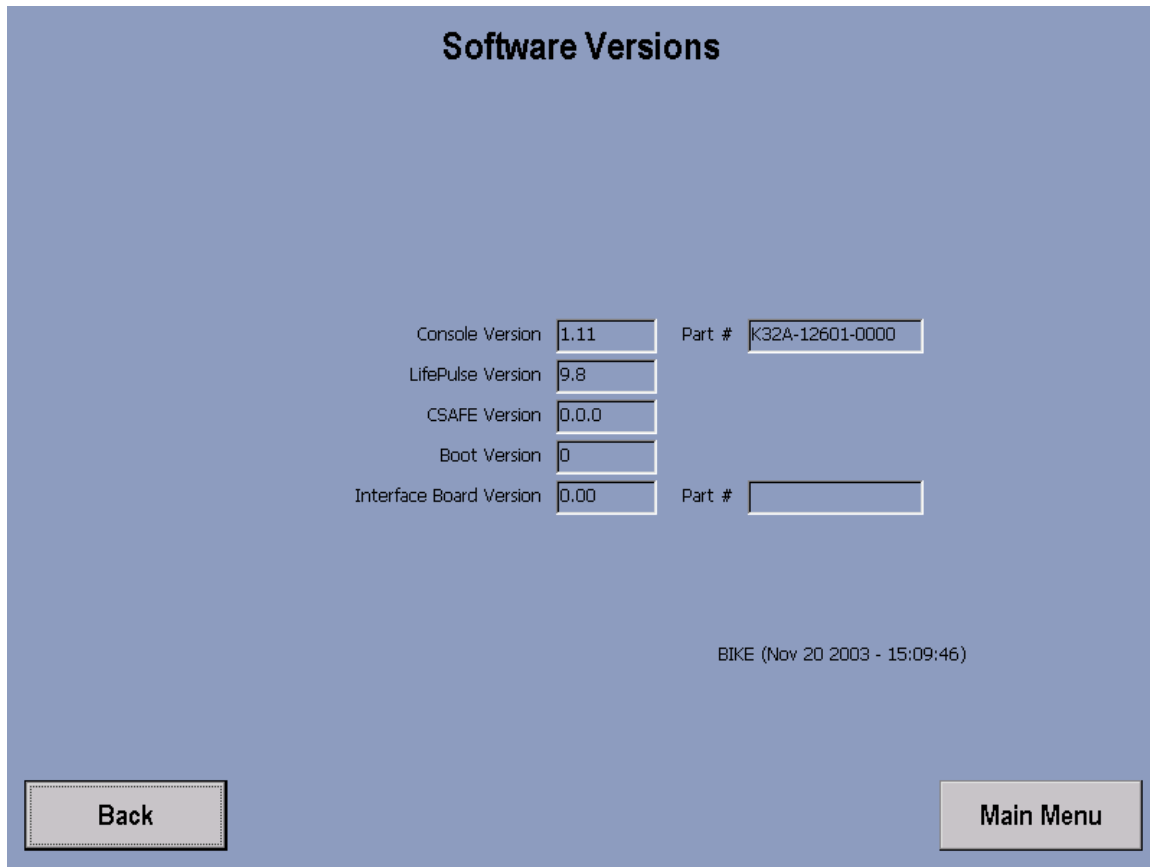

Note: Values shown are for reference only.

This screen allows the user to view the current software programs loaded into the unit along with its corresponding Life Fitness part number if applicable.

Pressing the screen Back key will return you to System Options – Main Menu screen. Pressing the screen MAIN MENU key will return you back to the MAIN MENU.

**Independent Stairclimbers SC95, SC91, SC85, SC9i, 95Si, 93Si, 90S, and 95Se
DISPLAY CONSOLE 95Ce LCD**

SYSTEM ERRORS

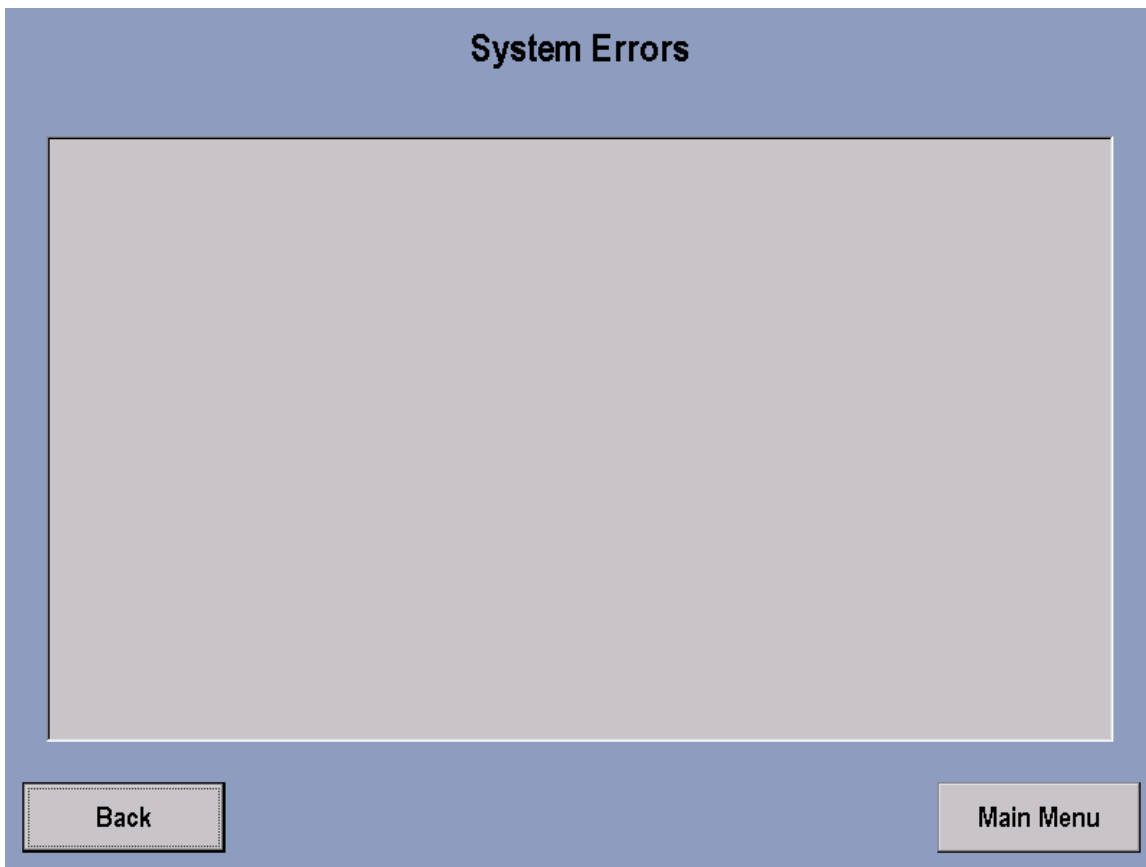

This screen allows the user to view system errors that have been logged into the unit's memory.

Pressing the screen Back key will return you to System Options – Main Menu screen. Pressing the screen MAIN MENU key will return you back to the MAIN MENU.

**Independent Stairclimbers SC95, SC91, SC85, SC9i, 95Si, 93Si, 90S, and 95Se
DISPLAY CONSOLE 95Ce LCD**

USAGE LOG REPORT

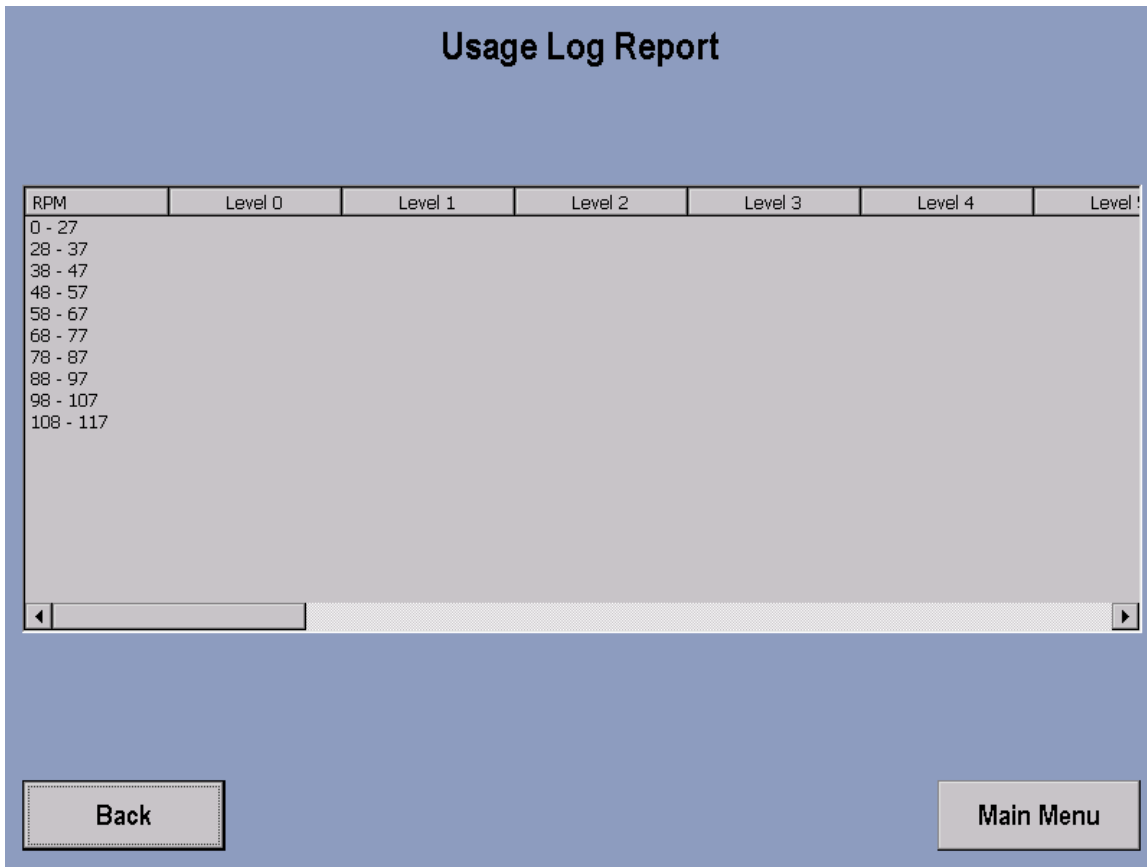

This screen allows the user to view detailed information in relation to RPMs used at different levels.

Pressing the screen Back key will return you to System Options – Main Menu screen. Pressing the screen MAIN MENU key will return you back to the MAIN MENU.

**Independent Stairclimbers SC95, SC91, SC85, SC9i, 95Si, 93Si, 90S, and 95Se
DISPLAY CONSOLE 95Ce LCD**

CONFIGURATION MENU

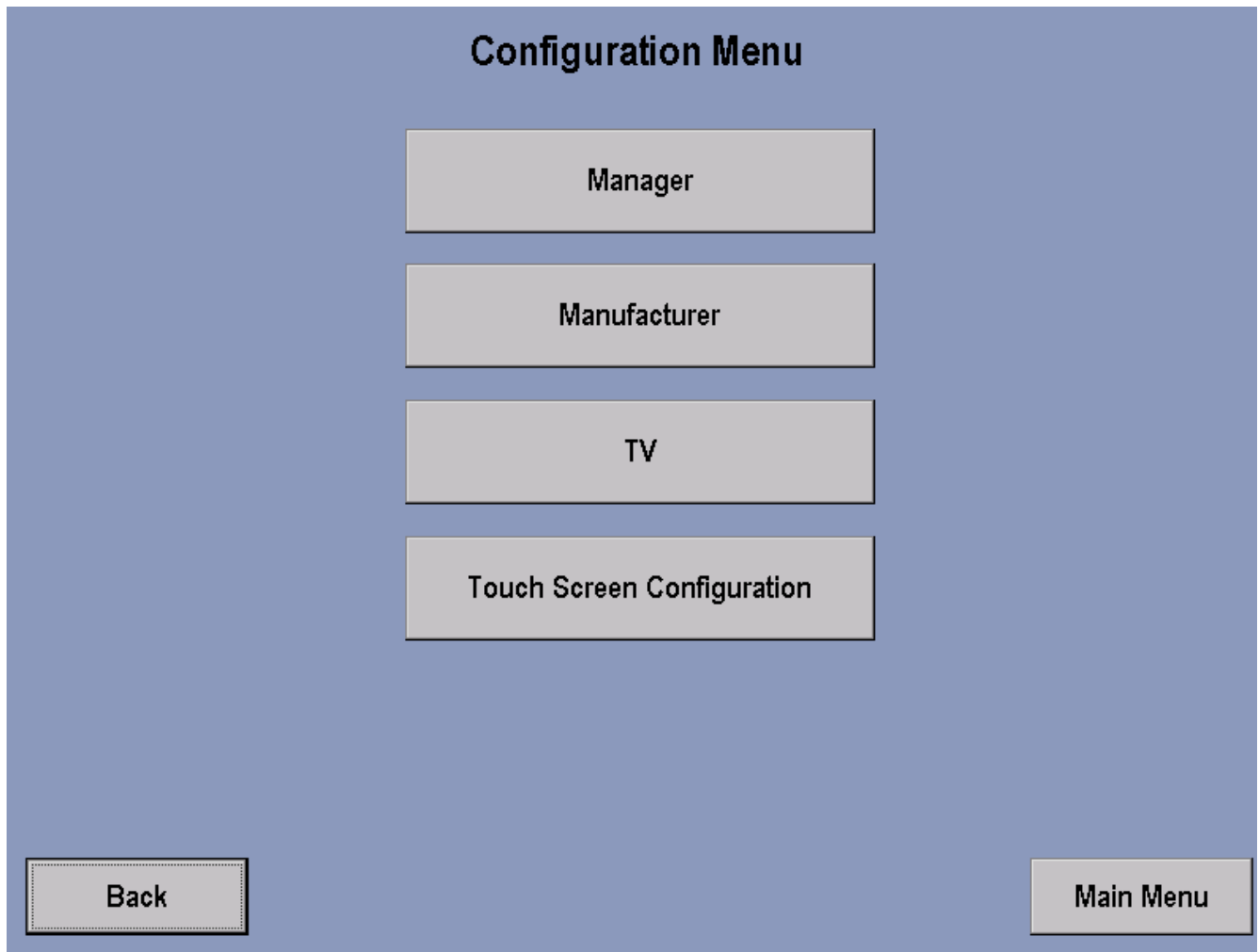

MANAGER	Supervisory workout parameter setup.
MANUFACTURER	Critical system parameter setup.
TV	Television configuration.
TOUCH SCREEN CONFIGURATION	Proximity calibration of touched screen.

Pressing the screen Back key will return you to System Options – Main Menu screen. Pressing the screen MAIN MENU key will return you back to the MAIN MENU.

Independent Stairclimbers SC95, SC91, SC85, SC9i, 95Si, 93Si, 90S, and 95Se
DISPLAY CONSOLE 95Ce LCD

MANAGER'S CONFIGURATION

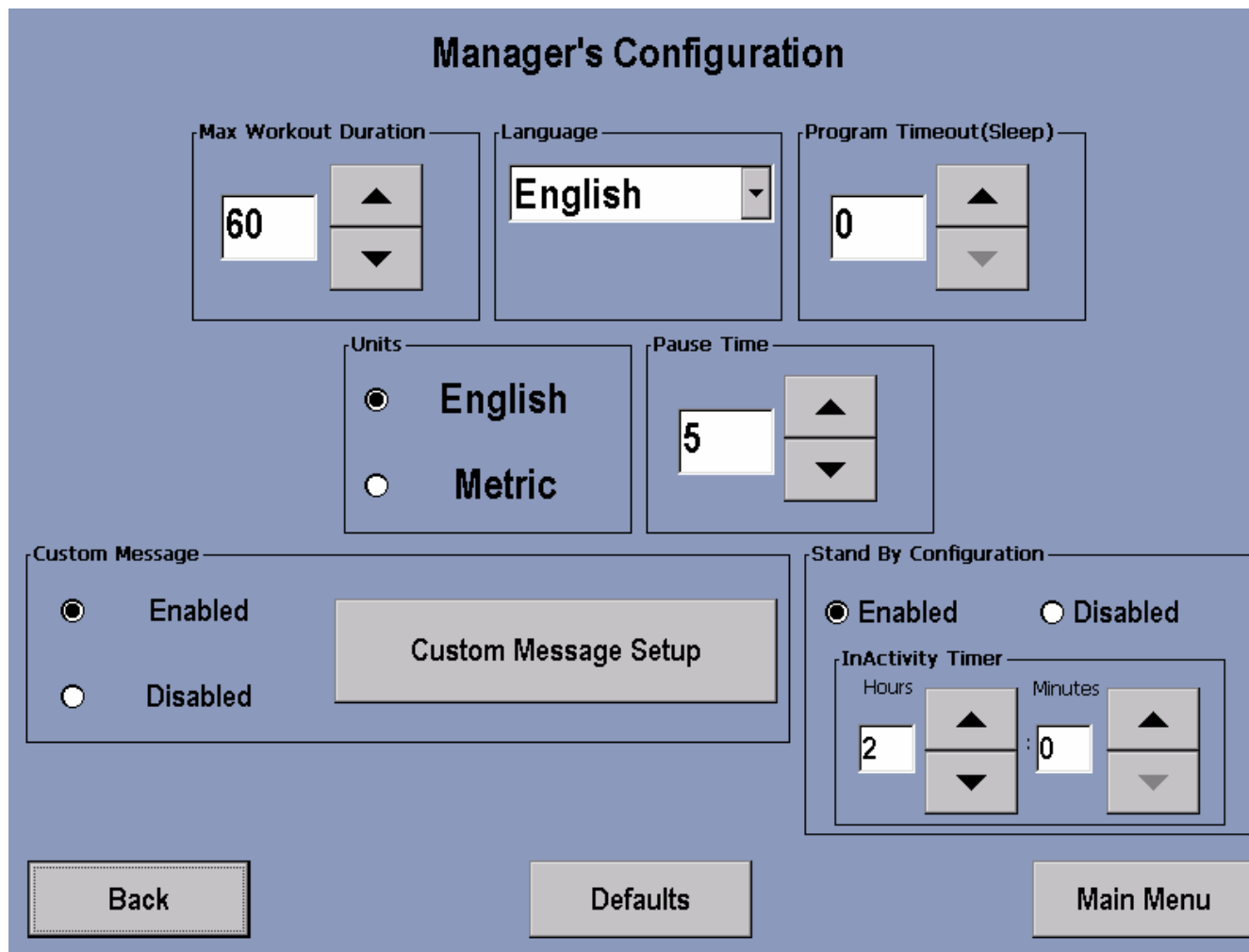

<p>Maximum Workout Duration: Allows the manager to set a maximum workout limit between 1 and 99 minutes. The time can be modified using the up or down arrow keys. The unit default is 60 minutes.</p>
<p>Standby Configuration: Sets the desired amount of time of inactivity before the system automatically turns the LCD screen backlight off. The LCD screen will illuminate the next time activity is detected. Inactivity Timer can be set from 0 to 24 hours.</p>
<p>Program Timeout: Sets the amount of time the user can go without touching the Touchscreen while setting up their workout, before the console resets back to the Welcome Screen. Program Timeout can be set from 20 to 255 seconds. The unit default is 60 seconds.</p>
<p>Pause Time: Set the amount of time the unit can be inactive before it reverts back to the Welcome Screen. Pause Time can be set from 1 to 99 minutes. The unit default is 1 minute.</p>
<p>Units: Choose between English and Metric.</p>
<p>Language: The language of the message area display. Choices include English, Portuguese, Spanish, Dutch, Japanese, Italian, French, and German.</p>
<p>Custom Message Setup: Allows for a custom message to be displayed across the Welcome Screen.</p>

Pressing the screen Back key will return you to System Options – Main Menu screen. Pressing the screen MAIN MENU key will return you back to the MAIN MENU.

Independent Stairclimbers SC95, SC91, SC85, SC9i, 95Si, 93Si, 90S, and 95Se DISPLAY CONSOLE 95Ce LCD

CUSTOM MESSAGE SETUP

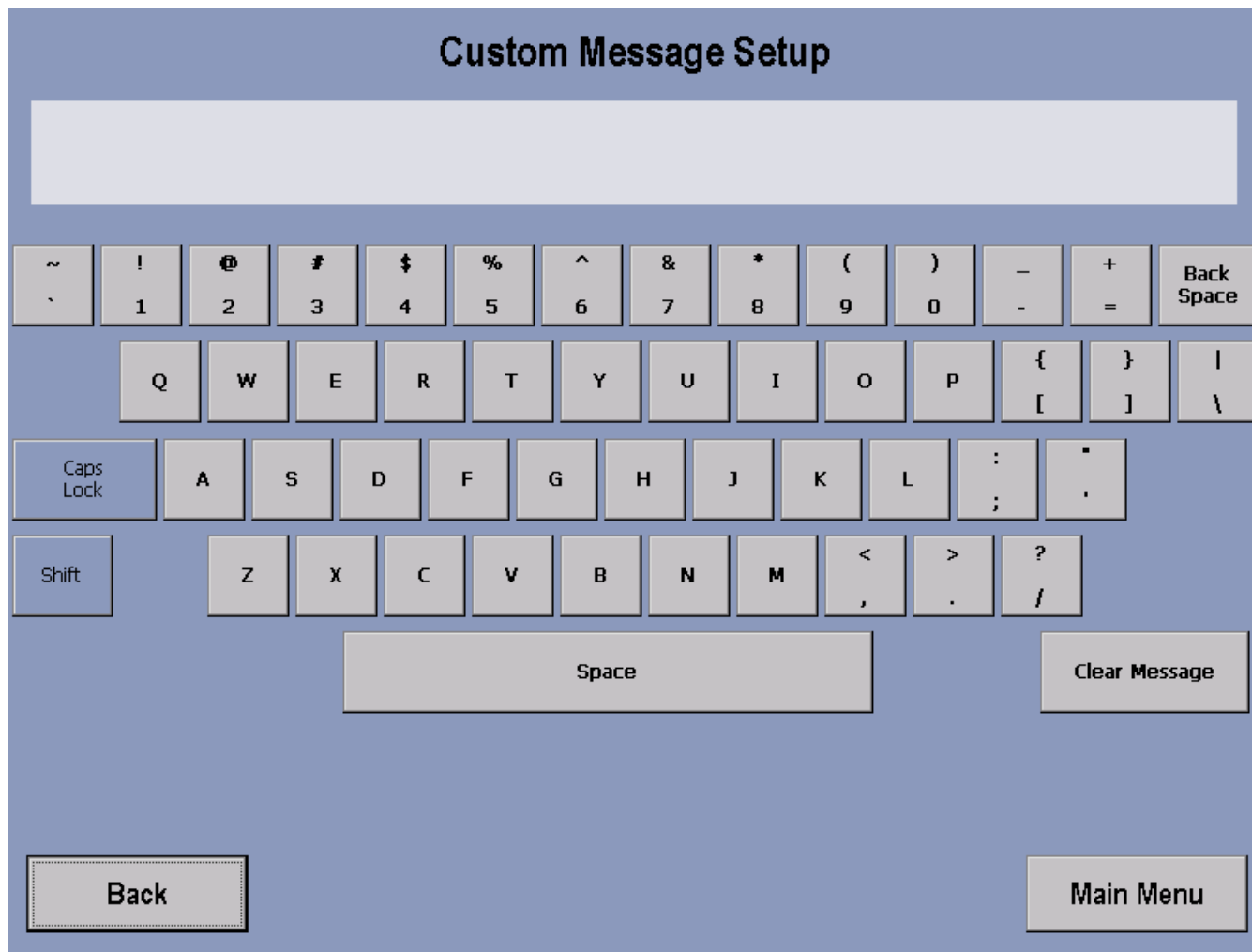

This configuration allows for a custom message to be displayed across the Welcome Screen. Creating/changing a Custom Message—after entering the Manager’s Configuration, check to make sure that Custom Message is enabled, and then select Custom Message Setup. Upon entering the setup screen, a message can be entered using the on-screen keyboard. Use the Shift button to input special characters and capital letters. The message will scroll across the top of the screen as the message is being inputted, giving real time feedback. Accepting a Custom Message—To accept the Custom Message, simply select the Main Menu button.

Erasing a Custom Message—to erase a Custom Message, enter the Custom Message Setup screen. Then select Clear Message and then Main Menu.

Pressing the screen Back key will return you to System Options – Main Menu screen. Pressing the screen MAIN MENU key will return you back to the MAIN MENU.

**Independent Stairclimbers SC95, SC91, SC85, SC9i, 95Si, 93Si, 90S, and 95Se
DISPLAY CONSOLE 95Ce LCD**

MANUFACTURERS CONFIGURATION MENU

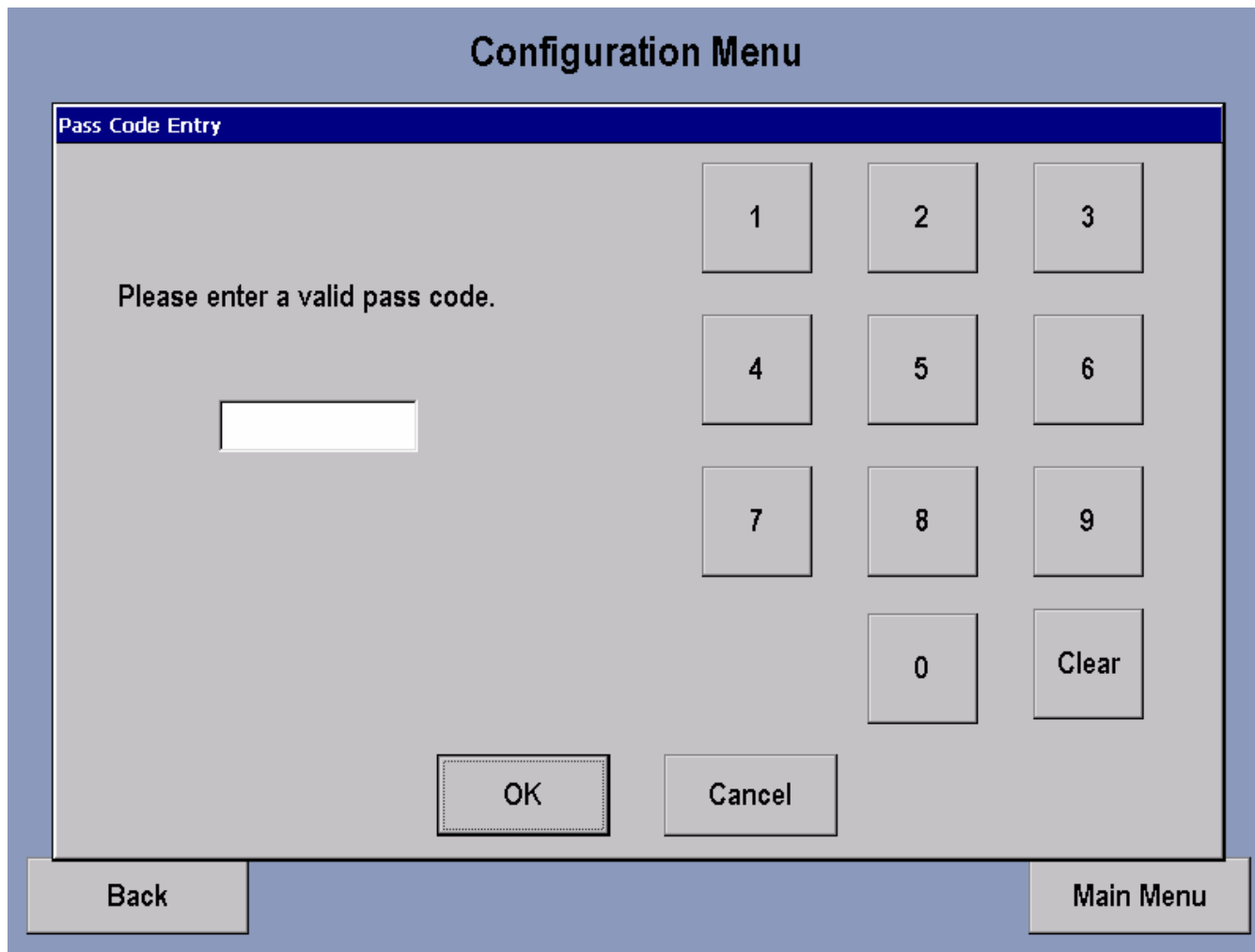

Access to this screen will only be available to Life Fitness certified technicians.

Pressing the screen Back key will return you to System Options – Main Menu screen. Pressing the screen MAIN MENU key will return you back to the MAIN MENU.

Independent Stairclimbers SC95, SC91, SC85, SC9i, 95Si, 93Si, 90S, and 95Se DISPLAY CONSOLE 95Ce LCD

TV CONTROLS

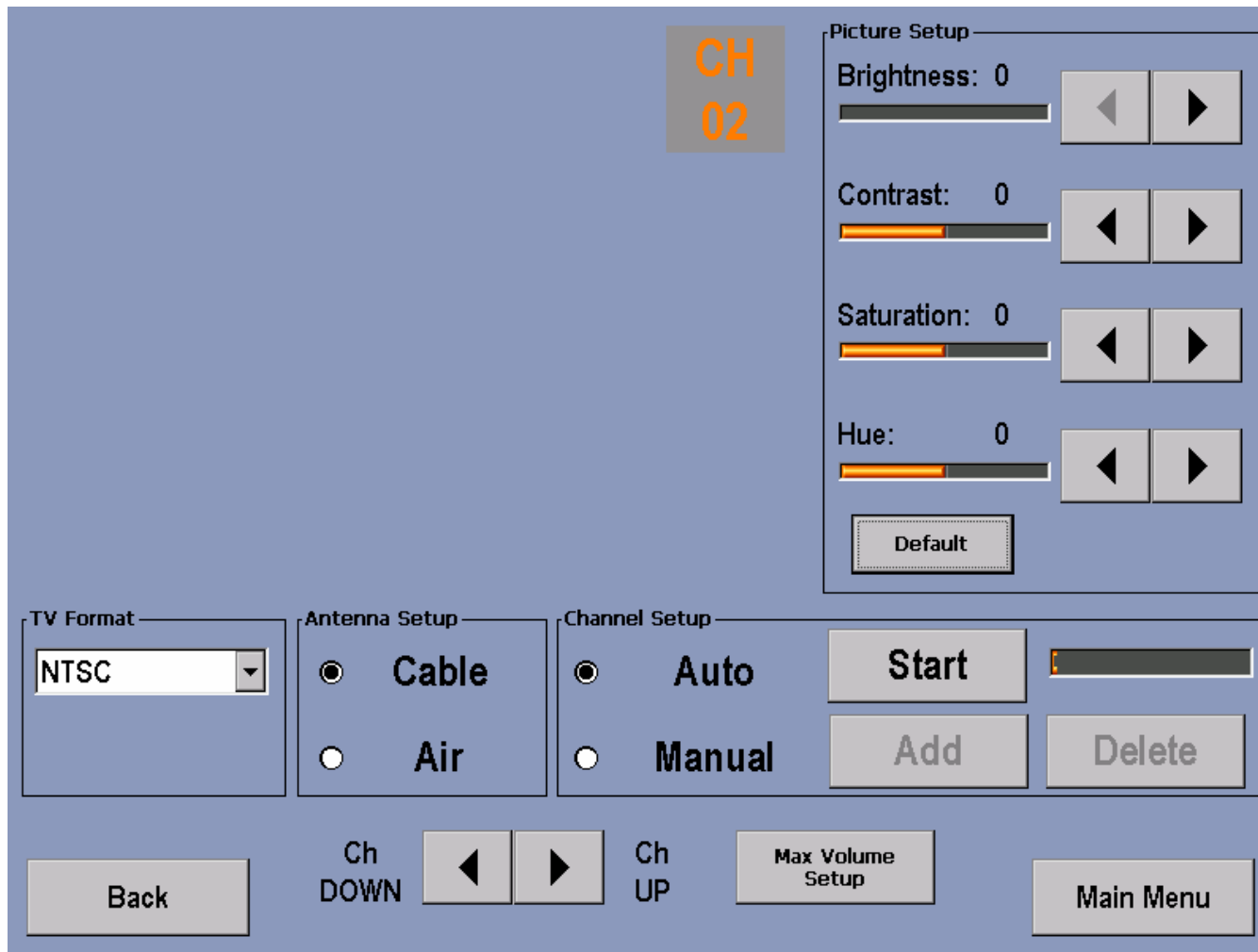

This screen brings up the TV screen and allows adjustment of brightness, contrast, saturation and hue. Also allows the choice of TV format, antenna setup and channel setup. To Set up channels: Select Auto in Channel Setup and then press Start.

To delete an unwanted channel: Select Manual in Channel Setup window, then press Manual, then use the channel controls on the Control Panel to choose the channel to be deleted, press Delete and then press Auto to return Channel Setup to Auto.

To restore a channel: Press the Manual key in Channel Setup, use the the channel controls to choose the channel to be restored, press the Add key and the press Auto to return Channel Setup to Auto.

To Adjust Picture Setup: Brightness, Contrast, Saturation and Hue can be adjusted by using the corresponding arrow buttons. To return to the unit default settings, press Default key. The default settings are: Brightness-180, Contrast-71, Saturation-64 and Hue-0.

Press the Max Volume Setup key to adjust volume.

Pressing the screen Back key will return you to System Options – Main Menu screen. Pressing the screen MAIN MENU key will return you back to the MAIN MENU.

**Independent Stairclimbers SC95, SC91, SC85, SC9i, 95Si, 93Si, 90S, and 95Se
DISPLAY CONSOLE 95Ce LCD**

MAX VOLUME SETUP

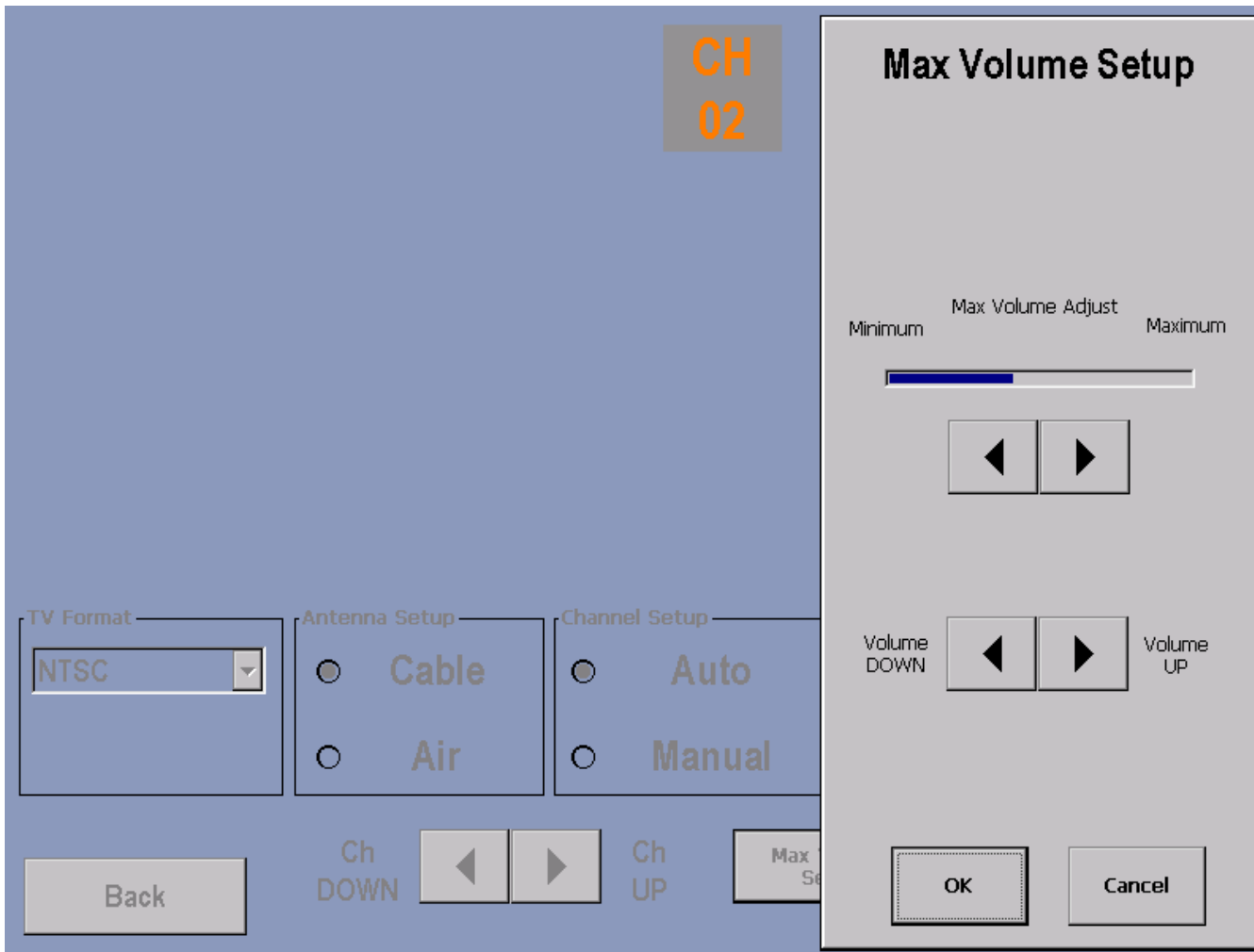

Entry to this screen allows the user to adjust Volume by using the Arrow keys.

Note: Headphones must be used for this function.

The upper set of arrows adjusts the volume capacity higher or lower, allowing clubs to compensate for average noise levels within the club. The maximum volume returns to this default after each workout. The Volume Down, Volume Up arrows control the volume of the unit for the current usage. After each session ends, the unit resets to mid-range volume corresponding to the maximum volume setup.

Pressing the screen Back key will return you to System Options – Main Menu screen. Pressing the screen MAIN MENU key will return you back to the MAIN MENU.

Independent Stairclimbers SC95, SC91, SC85, SC9i, 95Si, 93Si, 90S, and 95Se
DISPLAY CONSOLE 95Ce LCD

TOUCH SCREEN CONFIGURATION

Entry into this screen will allow to user to reconfigure the Touch Screen. The display will show a blank screen with a + sign in the middle. Follow the directions at the top of the screen to properly reconfigure the Touch Screen. This procedure may have to be repeated more than once. Once the screen has been successfully calibrated the screen will exit calibration state automatically.

SECTION III

How To...

SERVICE AND REPAIR

	Page
Side Shrouds.....	3
Battery	4
Recharge Battery	5
Alternator.....	6
Alternator Brush	7
Alternator and Main Drive Belts.....	8
Tension the Alternator and Main Drive Belts.....	9
Crossover Pulley and Hub Assembly	10
Left Drive Clutch.....	11
Right Drive Clutch	12
Pulley/Shaft and Shaft Bearings.....	13
Belt and Spring Guide Pulleys.....	17
Belt Spring Assembly	18
Pedals, Pedal Assembly, and Rail	19
Side and Mono Rollers	20
Magnetic Auto Start Switch	21
Overlay Bezel.....	22
Bullhorns	23
Front Wheel Assembly	24
Telemetry Receiver	25
Leg Levelers.....	26
Mono-Column.....	27
Power Control Board PCB.....	28
Resistor Assembly.....	29
Return Springs	30
LCD Integrated Console Service Overview.....	32
Headphone Jack	33
Inverter Board.....	34
Single Board Computer	35
Interface Board.....	36
Touch Screen Assembly	37

Independent Stairclimbers SC95, SC91, SC85, SC9i, 95Si, 93Si, 90S, and 95Se

Notes

Independent Stairclimbers SC95, SC91, SC85, SC9i, 95Si, 93Si, 90S, and 95Se

How To... Replace the Side Shrouds

Special Service Tools: None

1. Remove four screws securing the mono-column shroud.
2. Lift the mono-column shroud up the mono-column and secure it up out of the way.
3. Remove five screws from the right shroud, and then remove the shroud from the machine.
4. Remove four screws securing the left shroud. Carefully pull the left shroud back just enough to reach in and disconnect the power jack lead wire from the PCB Board.
5. Install new covers in reverse order. Before installing the left shroud, make sure to reconnect the power jack to the PCB Board, and then secure side shrouds. Do Not over-tighten shroud screws.

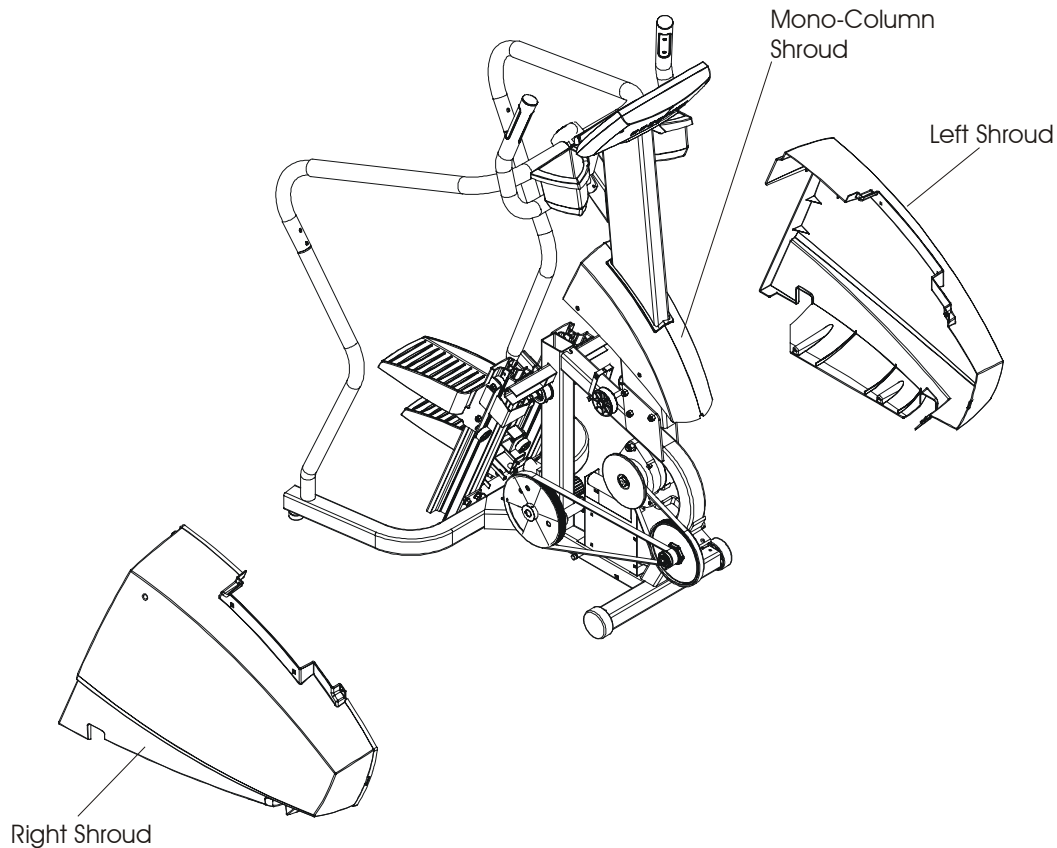
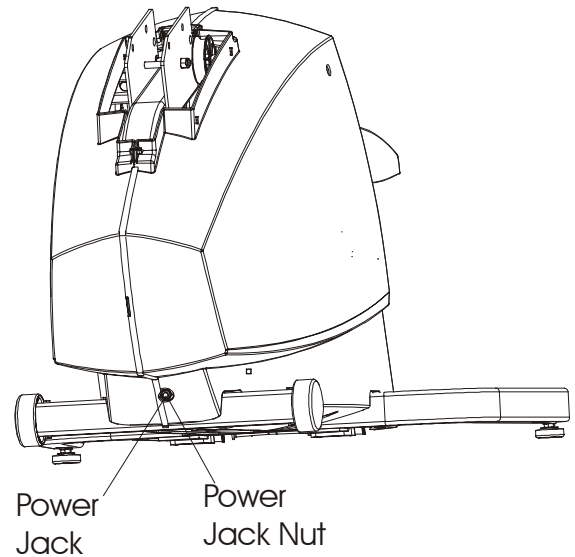

Life Fitness Independent Stairclimber SC9500HR, SC9100, SC8500, and S9i How To... Replace the Battery (SC9500, SC9100, and SC8500 only)

Special Service Tools: None

1. Remove two screws from the front cover (between the pedals).

NOTE: Side shrouds removed for clarity.

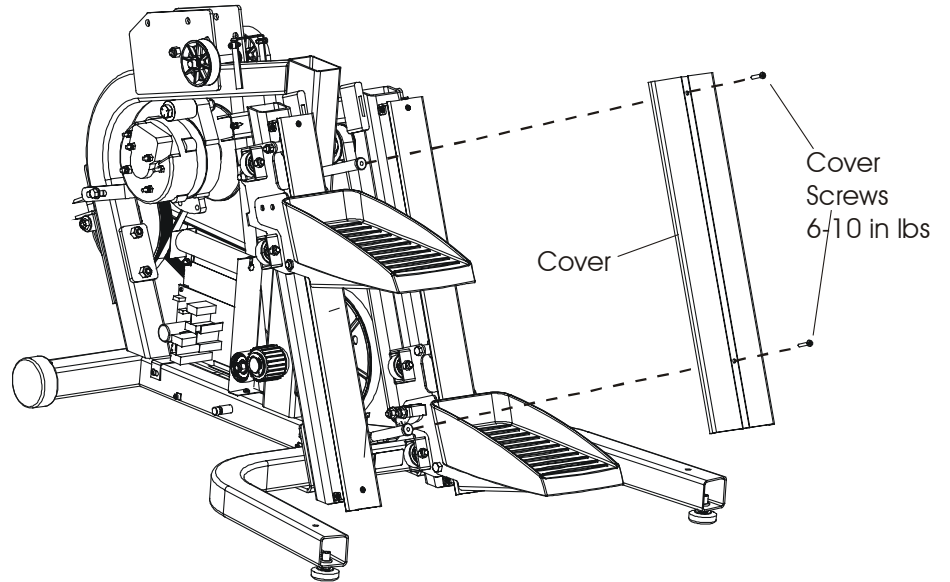

2. Disconnect the Red (+) positive and Black (-) negative battery wires.
3. Remove 2 screws securing battery to frame
4. Remove the TORX screws from the battery, and then remove the battery and discard.
5. Install new battery in reverse order. Make sure to reconnect battery wires to their respective positive and negative terminals. Red goes to (+) and Black to (-).

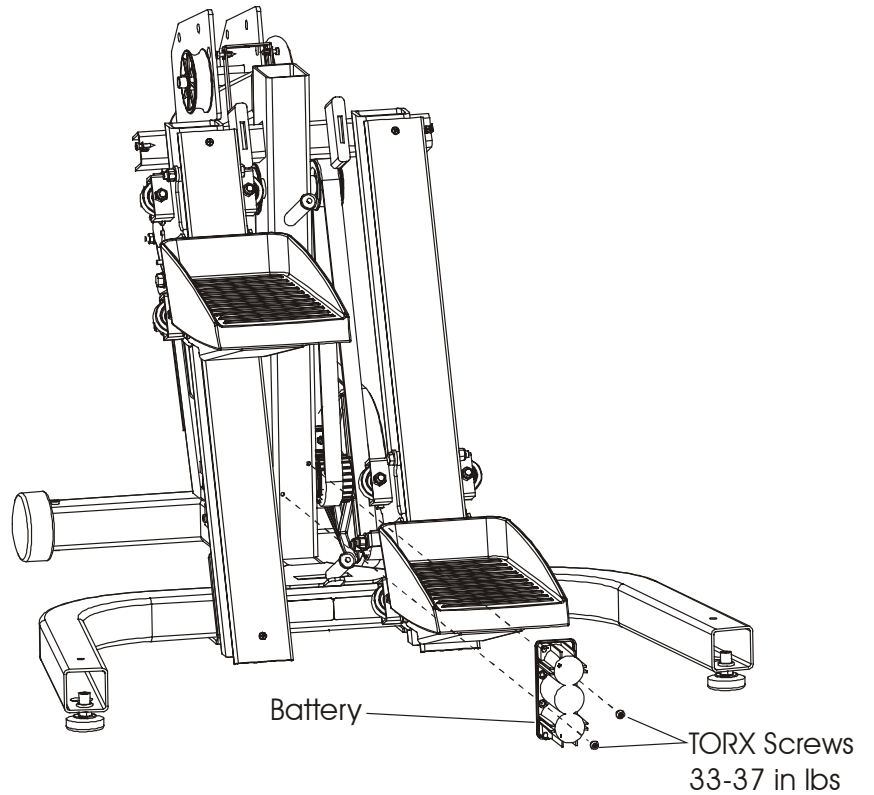

Life Fitness Independent Stairclimber SC9500HR, SC9100, SC8500, and S9i **How To... Recharge the Battery (SC95, SC91, and SC85 only)**

Special Service Tools: None

1. Plug the battery charger AC cord into the wall outlet. Make sure that the wall outlet has been properly installed and grounded in accordance with all local codes and ordinances.
2. Plug the charging cable into the power jack, located in the lower front of the left shroud (near the floor).
3. Charge the battery over-night, at least once every week to ensure its longevity.

Note: Battery procedure above not required for S9i.

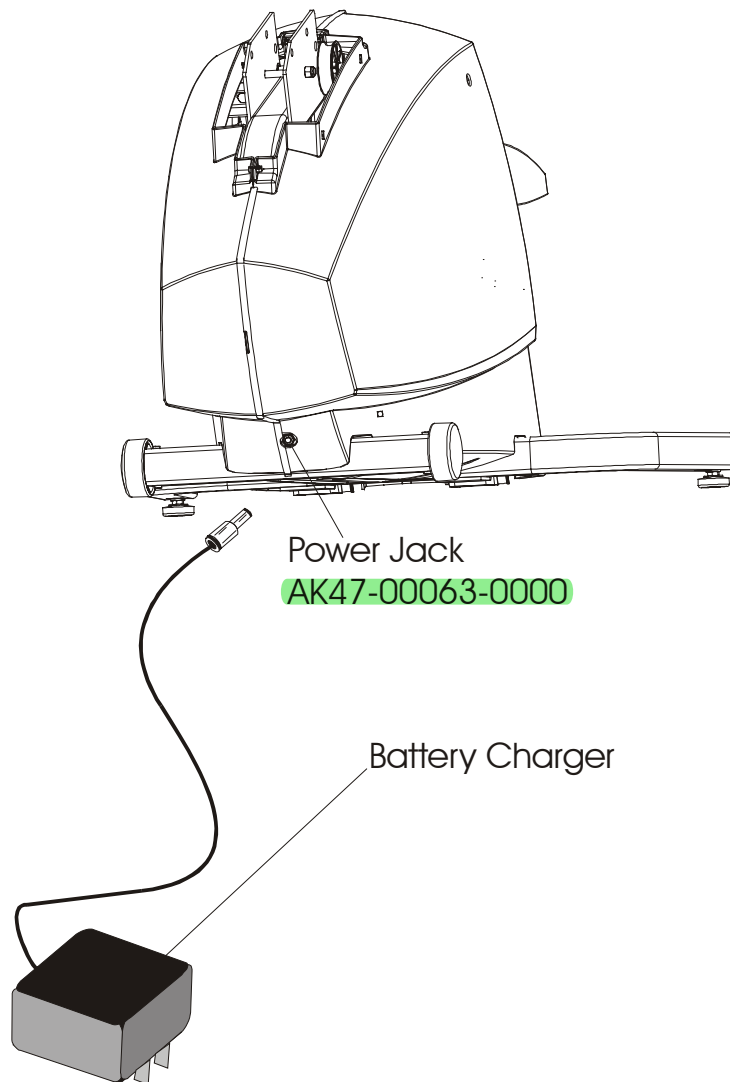

Life Fitness Independent Stairclimber SC9500HR, SC9100, SC8500, and S9i How To... Replace the Alternator

Special Service Tools: None

1. Remove Side Shrouds. See How To...in this section.
2. Tag and identify each alternator wire on the alternator terminals before removing, then remove the hex nuts securing each of the alternator wires from their terminals.
3. Loosen the alternator pivot bolt.
4. Remove the alternator tensioning bracket bolt.
5. Rotate the alternator until the alternator belt is loose enough to remove from pulley.
6. Remove the pivot bolt from the alternator, and then remove the alternator out from the users left side.
7. Install new alternator in reverse order.
8. Tension alternator belt. See How To...in this section.
9. Reconnect alternator wires.
10. Reinstall side shrouds.

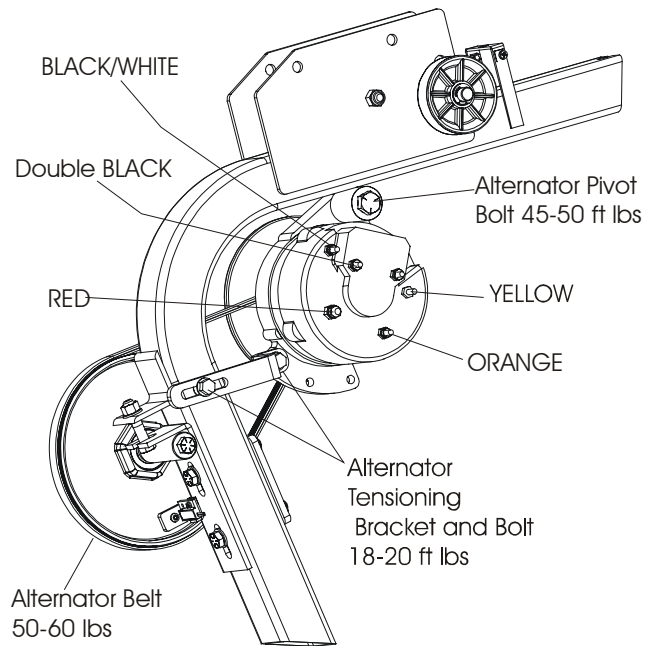

Life Fitness Independent Stairclimber SC9500HR, SC9100, SC8500, and S9i

How To... Replace the Alternator Brushes

Special Service Tools: None

Note: The alternator does not require removal.

1. At the back of the alternator, remove brush cover by removing the screw and two hex nuts, and lift off the cover.

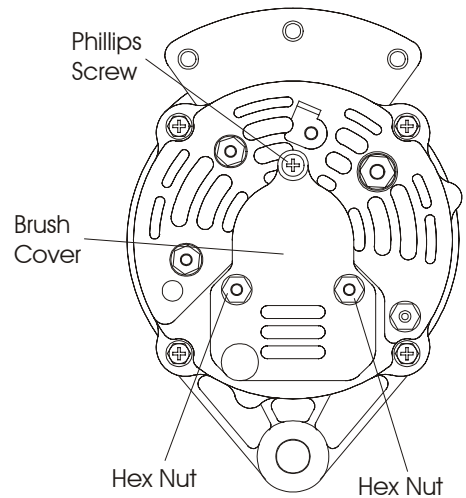

2. Remove the two mounting screws securing the brush assembly.
3. Remove the brush assembly with attached cover screws and seal, and discard.
4. Install new brush holder with attached cover screws and seal. Make sure the seal and brushes are seated properly before tightening down the brush holder.

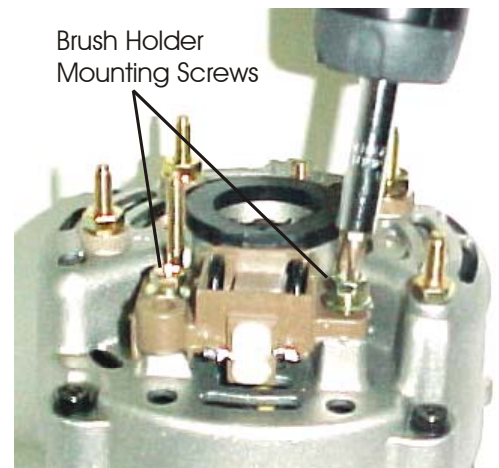

Removing Brush Holder Screw(2)

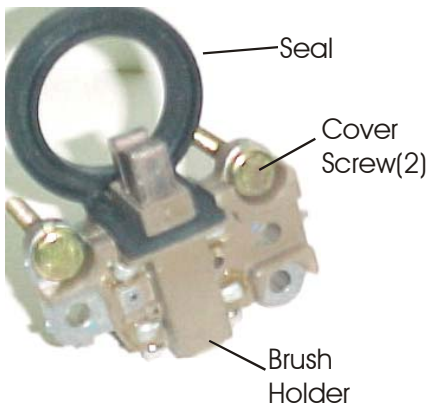

5. Secure the brush holder into position with the mounting two screws.
6. Install the cover and secure with the screw and two nuts.



Installing Brush Assembly with Cover Screws and Rubber Seal

Life Fitness Independent Stairclimber SC9500HR, SC9100, SC8500, and S9i

How To... Replace the Alternator and Main Drive Belts

Special Service Tools: None

1. Remove Side Shrouds. See How To...in this section.
2. Loosen the alternator tensioning bracket bolt.
3. Loosen the alternator pivot bolt.
4. Rotate the alternator until the alternator belt is loose enough to remove.
5. Scribe a mark on frame locating the adjustable bracket.
6. Loosen two bolts on the adjustable bracket, and then loosen the bracket tensioning bolt.

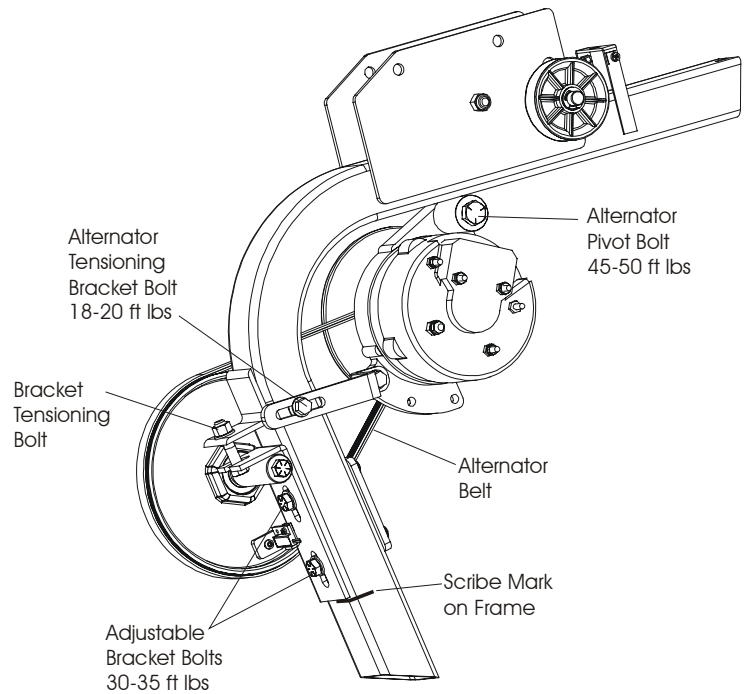

7. Remove the main drive belt and then the alternator belt.
8. Install new belts in reverse order of removal.
9. Re-tension these belts. See How To... in this section.

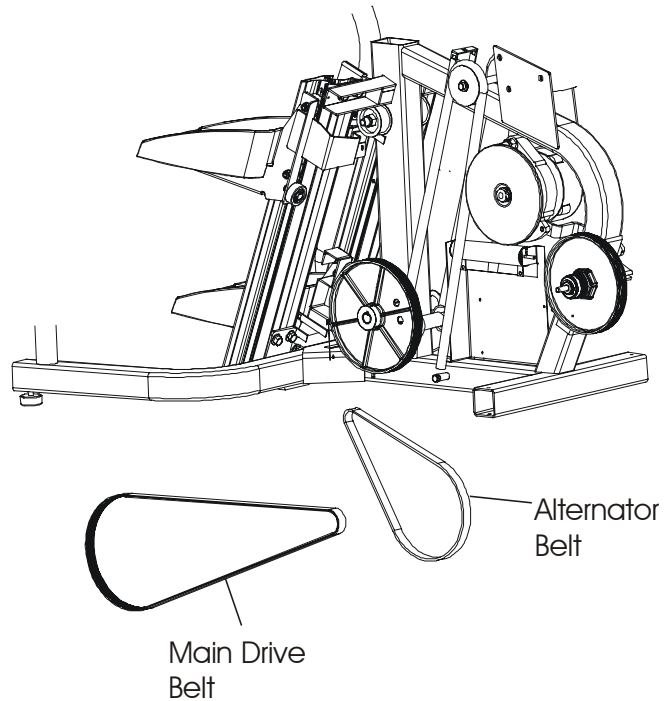

Life Fitness Independent Stairclimber SC9500HR, SC9100, SC8500, and S9i

How To... Tension the Alternator and Main Drive Belts

Special Service Tools: None

Note: The main drive belt must be tensioned first, then the alternator belt.

1. **Main Drive Belt:** Install belt-tensioning gauge (J8) in the middle of the widest span on the main drive belt. Tighten the bracket tensioning bolt until the belt tension reaches 90-100 lbs, and then secure the bracket to the frame with the bracket bolts. Recheck tension after seating the belt.
2. **Alternator Belt:** Install belt-tensioning gauge (J6) in the middle of the widest span on the alternator belt.

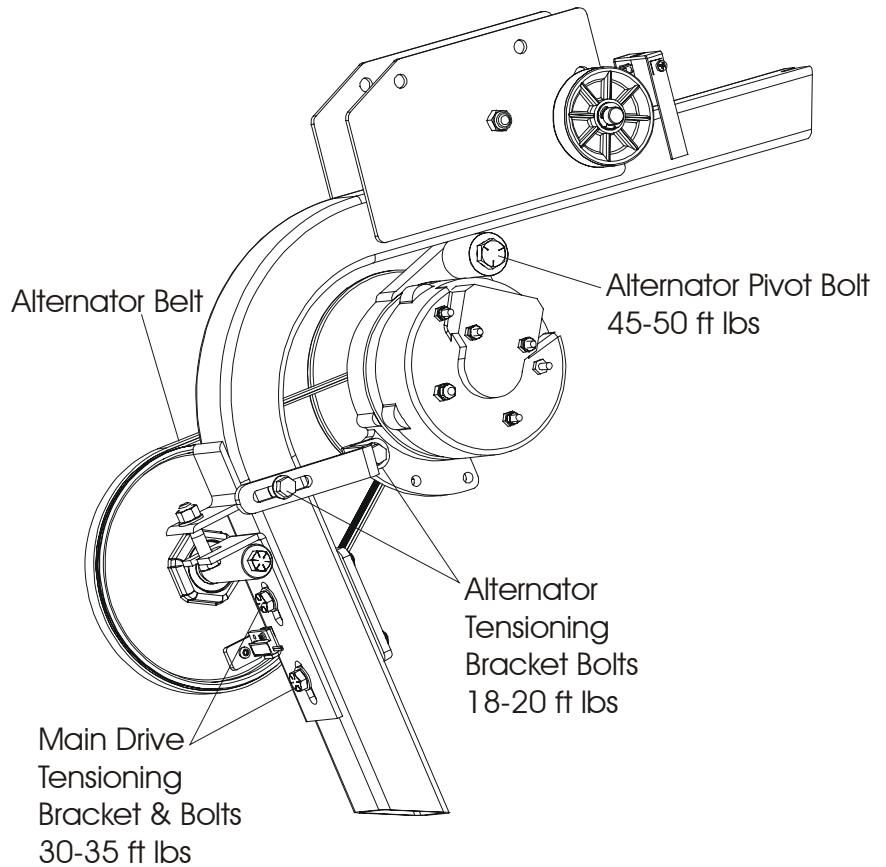

3. Secure a wrench to the alternator pivot nut. Then secure a second wrench to the alternator pivot bolt. With the wrench on the pivot bolt, press this wrench down against the top of the alternator while tightening the pivot bolt nut. Tension the alternator belt until the gauge reads 50-60 lbs and then tighten tension bracket bolts. Recheck tension after seating the belt.

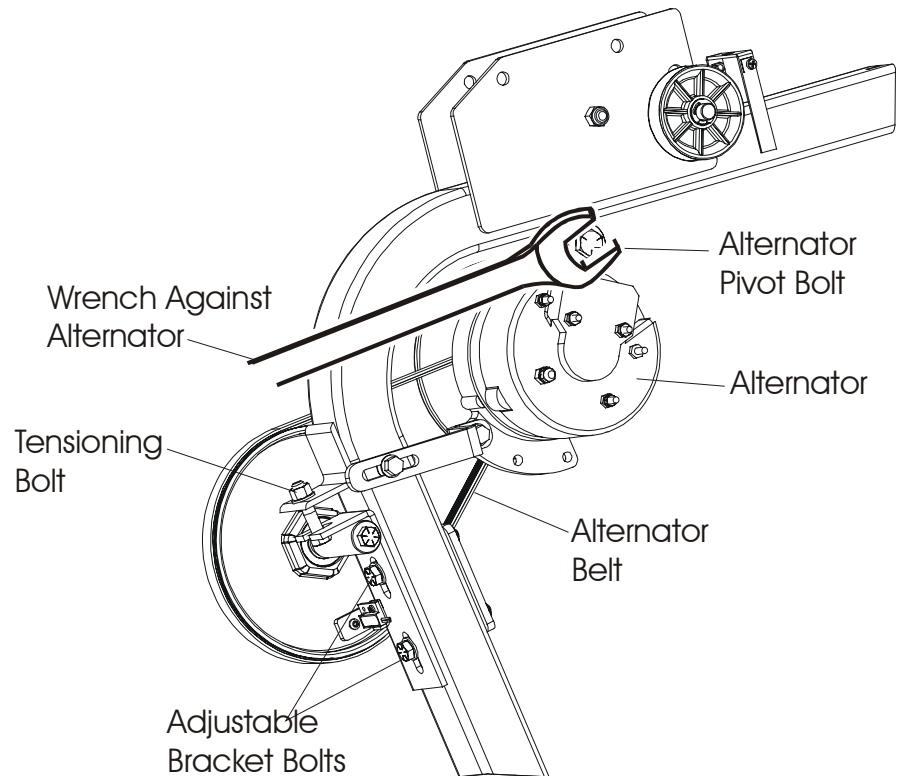

Life Fitness Independent Stairclimber SC9500HR, SC9100, SC8500, and S9i How To... Replace The Crossover Pulley and Hub Assembly

Special Service Tools: None

1. Remove Shrouds. See How to...in this section.
2. Remove the alternator and main drive belt. See How To... in this section.
3. Remove the bolt and nut from the crossover pulley, and remove the pulley and its attached components.
4. Install new crossover pulley in reverse order.
5. Install the belts and re-tension. See How To...tension belts in this section.

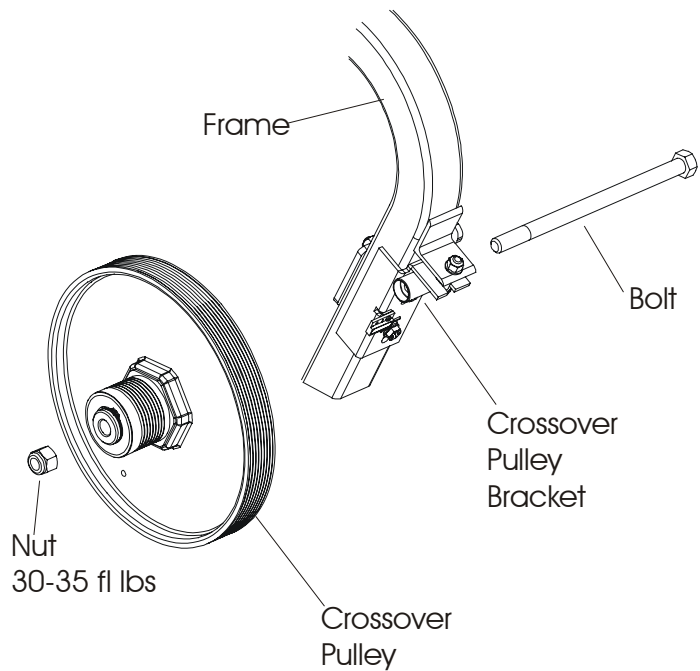

Life Fitness Independent Stairclimber SC9500HR, SC9100, SC8500, and S9i

How To... Replace Left Drive Clutch

Special Service Tools: None

1. Remove the left side shrouds. See How To...in this section.
2. Disconnect the belt and spring assembly at the bottom of the frame, and carefully lower the pedal to floor.

NOTE: Pedal assembly will drop when return belt and spring are detached.

3. On the left side of the unit, remove the outer E-ring, flat washer, thrust washer, and then remove the pulley clutch and discard.

4. Remove and discard the remaining inner thrust washers, flat washers, and E-ring from the shaft.

5. Install new left pulley clutch in reverse order.

Note: The left drive clutch has an arrow stamped on the outer race of the bearing. This arrow must face out, away from the frame so that it is visible when installed.

6. Reconnect the return belt and spring assembly.
7. Install the left shroud.

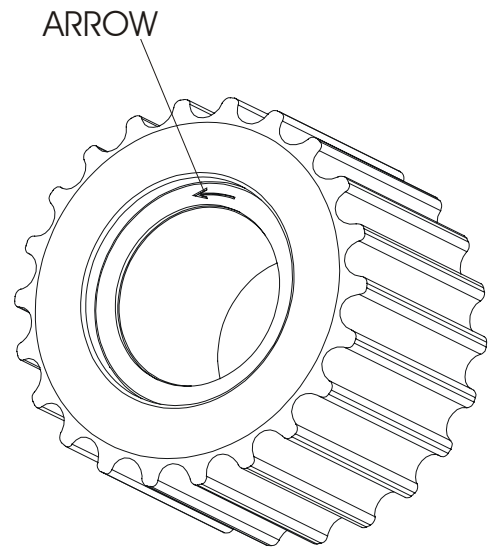
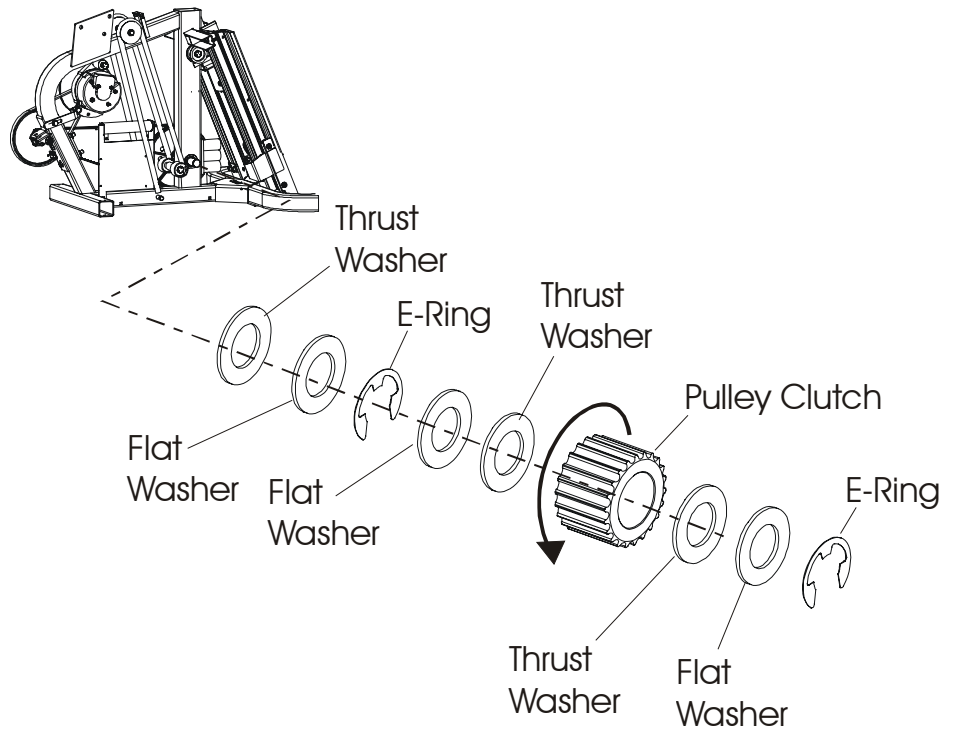

Drive Clutch - LT Side

Life Fitness Independent Stairclimber SC9500HR, SC9100, SC8500, and S9i

How To... Replace Right Drive Clutch

Special Service Tools: None

1. Remove the right side shroud. See How To... in this section.
2. Remove the main drive belt. See How To...in this section.
3. Disconnect the return spring and belt assembly at the bottom of the frame, and carefully lower the pedal to the floor.

NOTE: Pedal assembly will drop when belt spring assembly is detached.

4. Remove two setscrews from the main drive pulley, and then remove the pulley and machined key from the drive shaft.

ARROW MUST Face
The Frame (Not Visible)

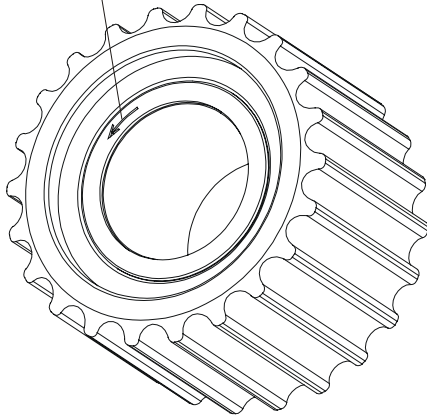

Drive Clutch - RT Side

5. Remove the right drive clutch from the shaft along with all its component parts, and then discard.
6. Install new drive clutch in reverse order with new hardware.

Note: The right drive clutch has an arrow stamped on the outer face of the bearing. This arrow must face in, towards the frame so that it is not visible when installed. See illustration above.

7. Reinstall main drive belt and then retention the main drive and alternator belts.
8. Install right shroud.

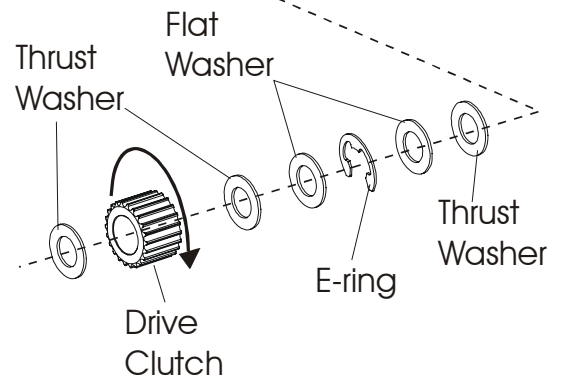
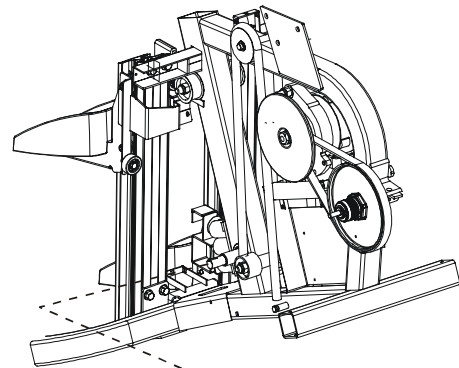
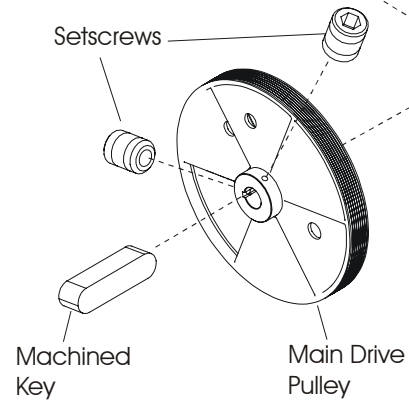
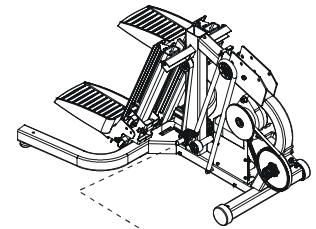

Life Fitness Independent Stairclimber SC9500HR, SC9100, SC8500, and S9i

How To... Replace the Pulley/Shaft and Shaft Bearings

Special Service Tools: Clutch Shaft Bearing Tool Kit

1. Remove the side shrouds.
See How To...in this section.
2. Loosen the alternator belt.
See How To... in this section.
3. Remove main drive belt.
See How To...in this section.
4. Disconnect the belt spring assembly at the bottom of the frame on both sides of the unit, and carefully lower the pedals to floor.

NOTE: Pedal assemblies will drop when both return belt and spring assemblies are detached.

5. On the left side of the unit, remove the outer E-ring from the shaft, and then remove the outer flat washer and thrust washer, and pulley clutch. Now remove the inner thrust washer, flat washer, E-ring, flat washer, thrust washer from the shaft.

Note: The left side drive clutch has an arrow stamped on the outer race of the bearing which faces the non-counterbore side of the drive clutch.

6. On the right side of the unit, pull out the main drive pulley with shaft and components, and then discard.

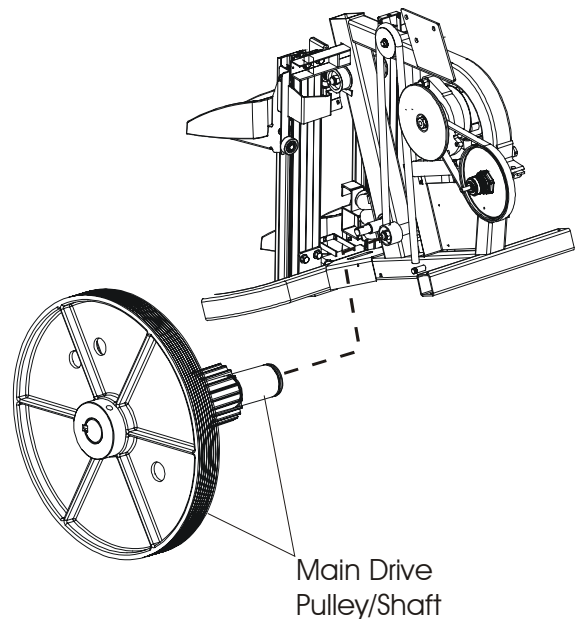
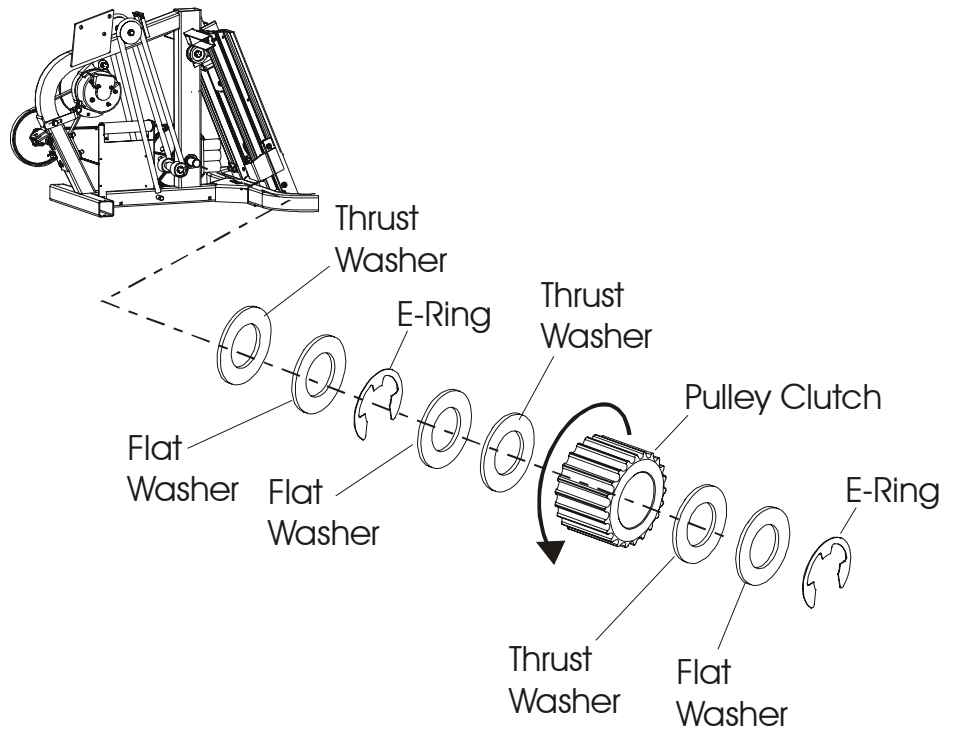

Life Fitness Independent Stairclimber SC9500HR, SC9100, SC8500, and S9i

How To... Replace the Pulley/Shaft and Shaft Bearings - Continued

Special Service Tools: Clutch Shaft Bearing Tool Kit

7. Install bearing press tool as illustrated, and begin to press out the bearings.

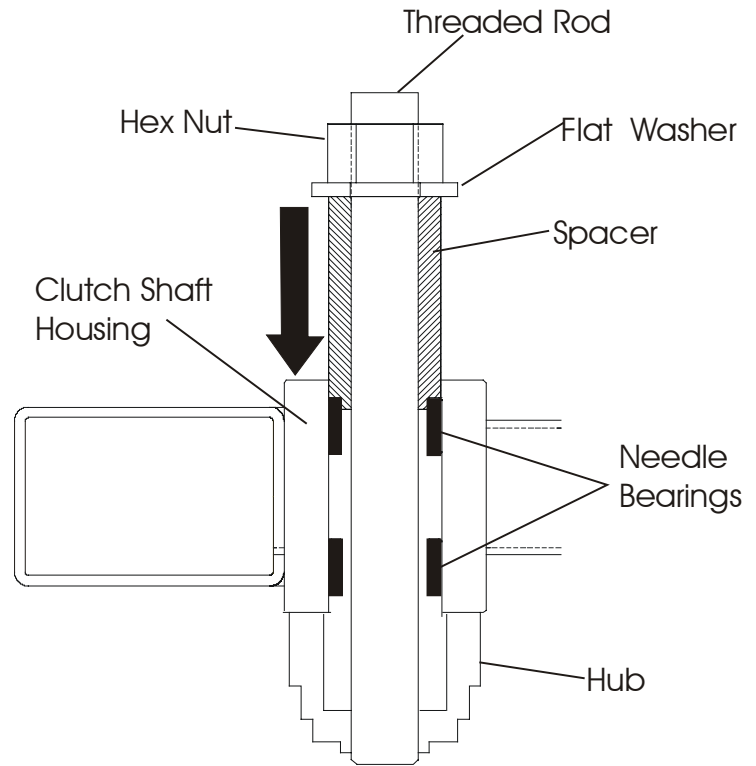

8. Press the needle bearings out of the frame and into the hub. Remove the tool and discard the bearings.
9. Clean the housing before installing new bearings.

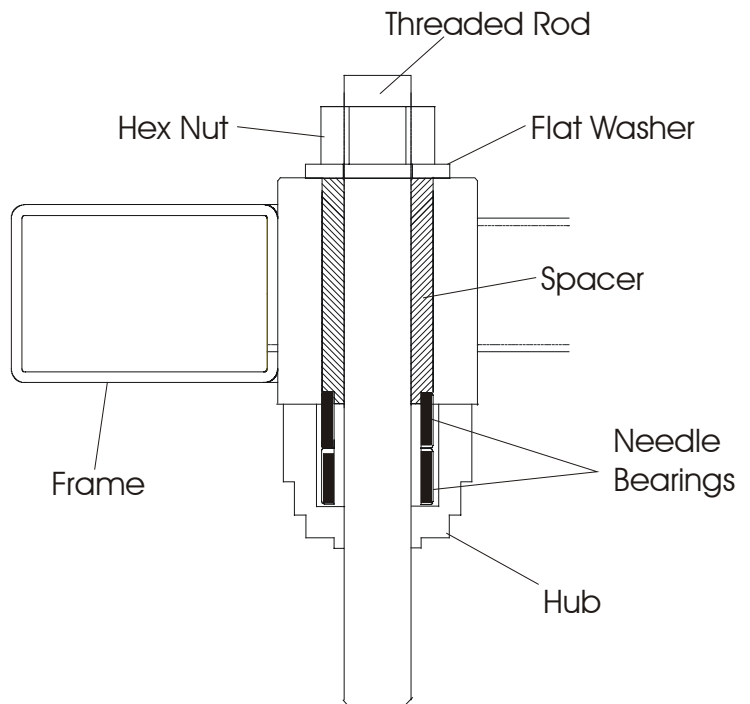

PUSHING OUT THE NEEDLE BEARINGS INTO THE HUB

Life Fitness Independent Stairclimber SC9500HR, SC9100, SC8500, and S9i How To... Replace the Pulley/Shaft and Shaft Bearings - Continued

Special Service Tools: Clutch Shaft Bearing Tool Kit

10. Position the first new bearing with markings facing out (away from the frame). Install the tool as illustrated making sure the bearing is aligned straight and square. Proceed to press in the first bearing flush to the frame. After pressing in the first bearing, remove the hub, position the 2nd bearing, reposition the hub, and in the 2nd bearing flush with the frame.

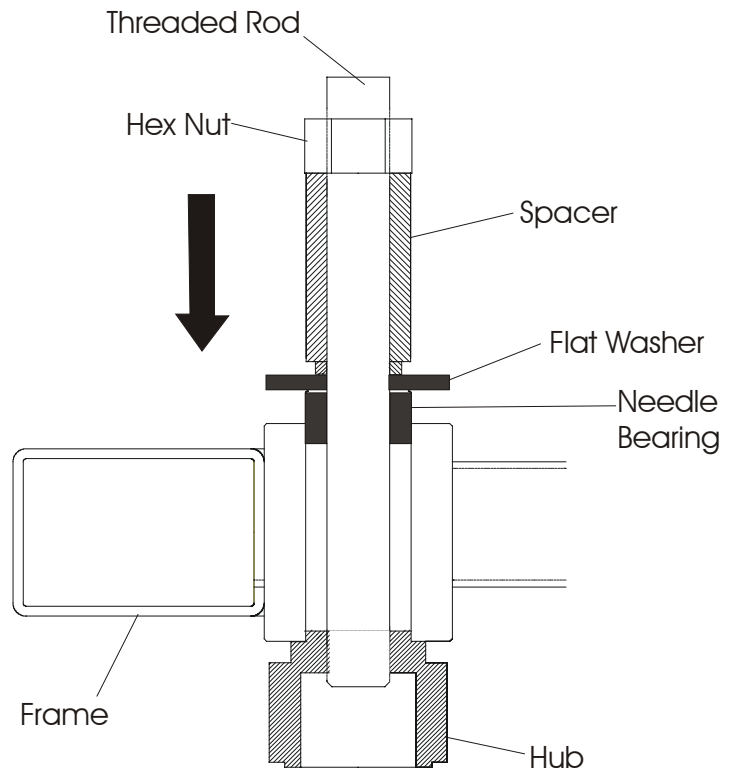

PRESSING IN NEW NEEDLE BEARING

11. With new shaft bearings installed, proceed to install the new pulley/shaft assembly.

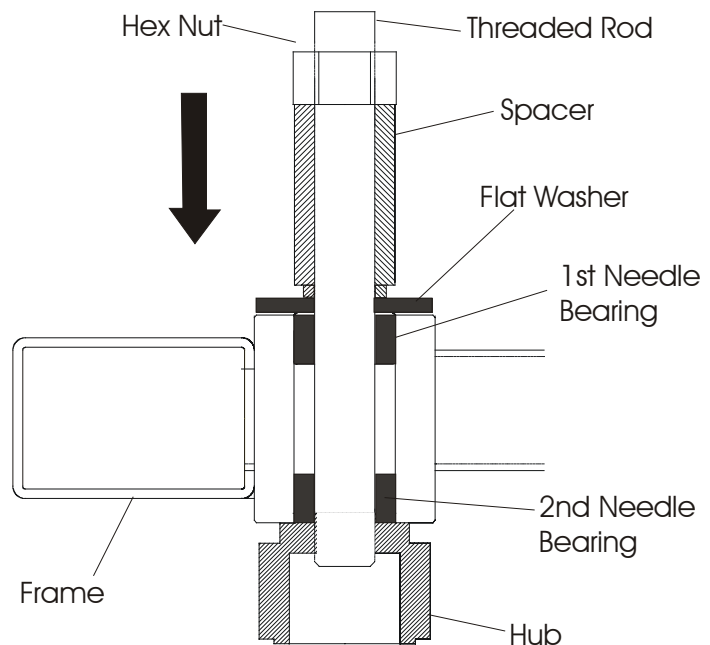

PRESSING IN 2nd NEW NEEDLE BEARING

Life Fitness Independent Stairclimber SC9500HR, SC9100, SC8500, and S9i How To... Replace the Pulley/Shaft and Shaft Bearings - Continued

Special Service Tools: Clutch Shaft Bearing Tool Kit

- 12. Reinstall the left clutch, washers, and e-rings onto the new shaft as shown.

Note: The left drive clutch has an arrow stamped on the outer race of the bearing. This arrow must face out, away from the frame so that it is visible when installed.

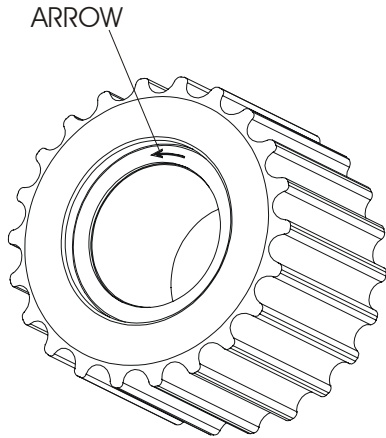

Drive Clutch - LT Side

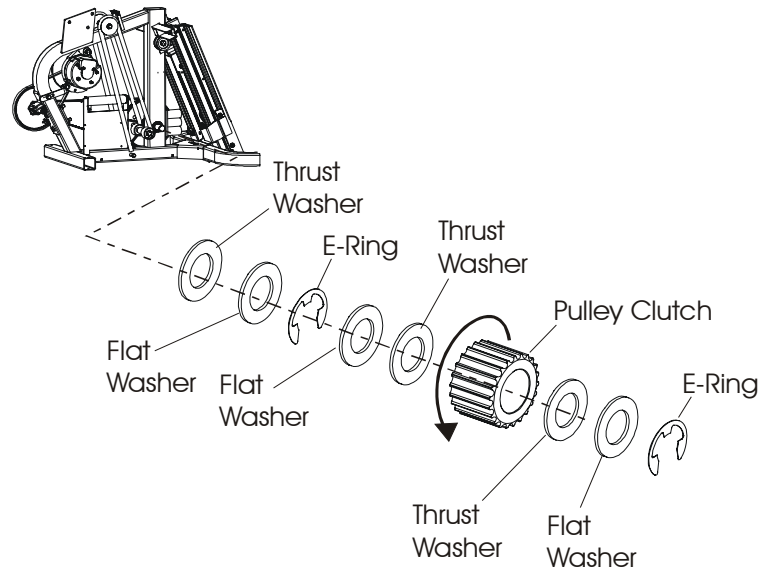

- 13. Reconnect the return belt and spring assemblies.
- 14. Install the main drive belt.
- 15. Re-tension the main drive and alternator belts. See How To...tension belts in this section.
- 16. Install shrouds.

Independent Stairclimbers SC95, SC91, SC85, SC9i, 95Si, 93Si, 90S, and 95Se

How To... Replace the Belt and Spring Guide Pulleys

Special Service Tools: None

(Upper Guide Idler)

1. Remove the side shrouds. See How To...in this section.
2. Disconnect the belt/spring assembly at the bottom of the frame, and lower the pedals on the floor.
3. Remove the upper bolt from the upper pulley, and remove the pulley.

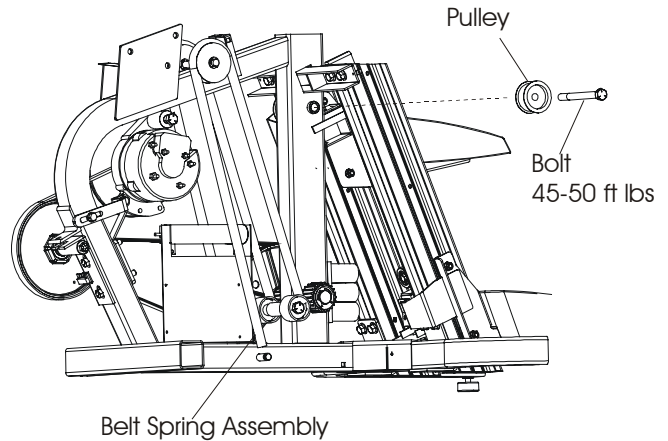

(Backside Idler)

4. Rotate the main drive pulley to align its access hole to the bottom Allen bolt of the lower belt guide pulley. Insert Allen wrench through the access hole and position a wrench on the nut side keep the bolt from turning, and remove the locknut from pulley on left side of the unit.
5. Remove the lower left belt pulley from the Allen bolt, and then pull the Allen bolt out through the main drive pulley access hole. The remaining pulley will drop out between the main drive pulley and right side of frame.
6. Install new backside idler pulley and position the new idler pulley towards the belt. Leave a .015-.045" clearance between the back side of the belt and pulley.

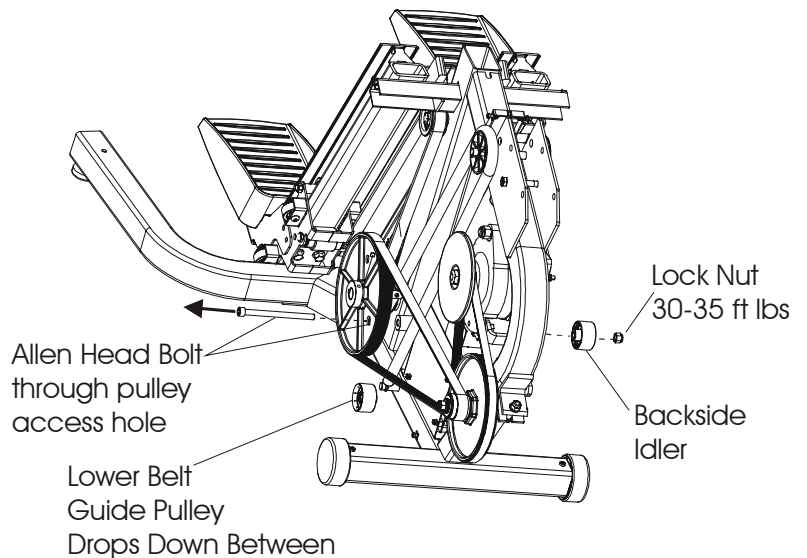

(Spring Guide Pulley)

7. If the spring guide pulleys require replacement, simply remove snap rings from the pulley shaft, and then remove the pulleys.
8. Install new pulleys in reverse order, re-route cog belts around pulley, and then reconnect the return springs to the bottom of the frame.

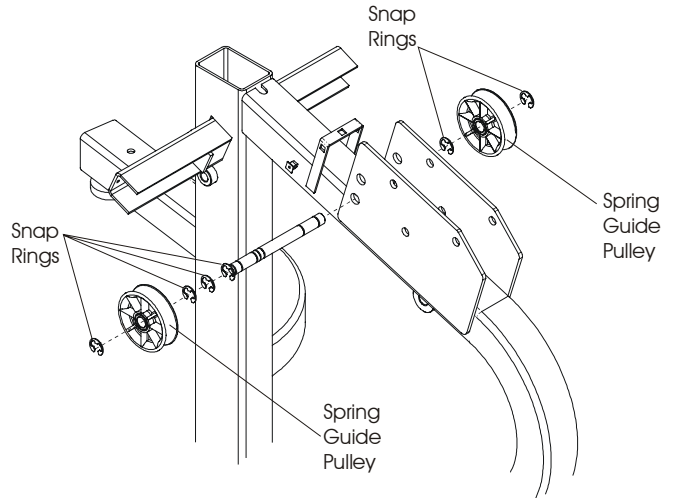

Independent Stairclimbers SC95, SC91, SC85, SC9i, 95Si, 93Si, 90S, and 95Se

How To... Replace the Belt Spring Assembly

Special Service Tools: None

1. Remove the side shrouds. See How To... in this section.
2. Disconnect the return spring at the bottom of the frame and lower the pedal to the floor.
3. Remove the pedal assembly with belt and spring attached as shown. See How To...remove pedal assembly in this section.

Note: The pedal assembly must be removed from the extrusion (rail) to gain access to the Allen head bolt for removing the lock nuts.

4. Remove lock nuts and washers from the Allen bolts at the clamp bracket.
5. Remove the belt from the belt terminator pulley.

Note: The belt and spring are sold as an assembly. DO NOT take apart.

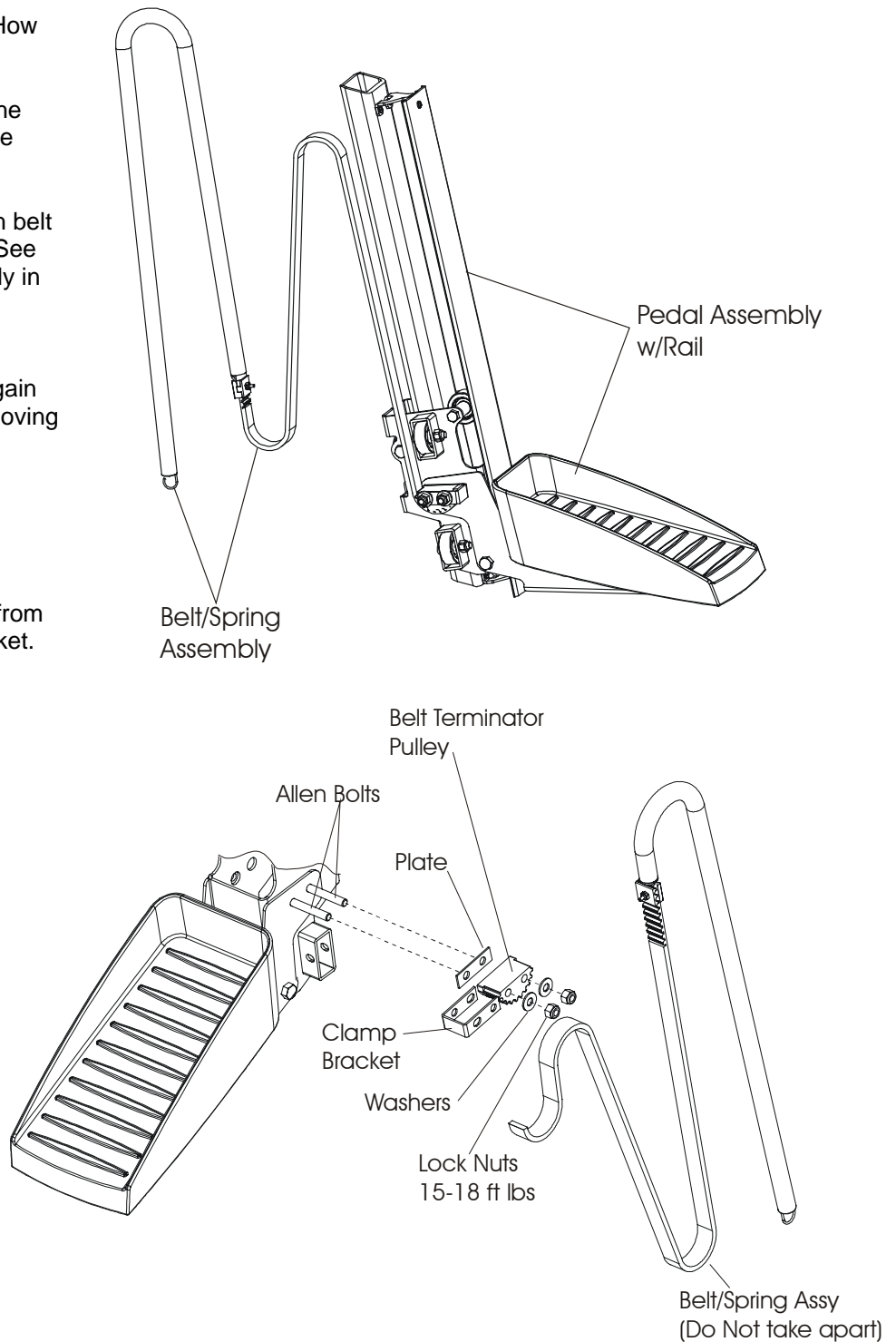

Independent Stairclimbers SC95, SC91, SC85, SC9i, 95Si, 93Si, 90S, and 95Se

How To... Replace the Pedals, Pedal Assembly, and Extrusion (Rail)

Special Service Tools: None

(Pedals)

1. Remove four screws from under the pedal support, and then lift off the pedal.
2. Install new pedal(s) in reverse order.

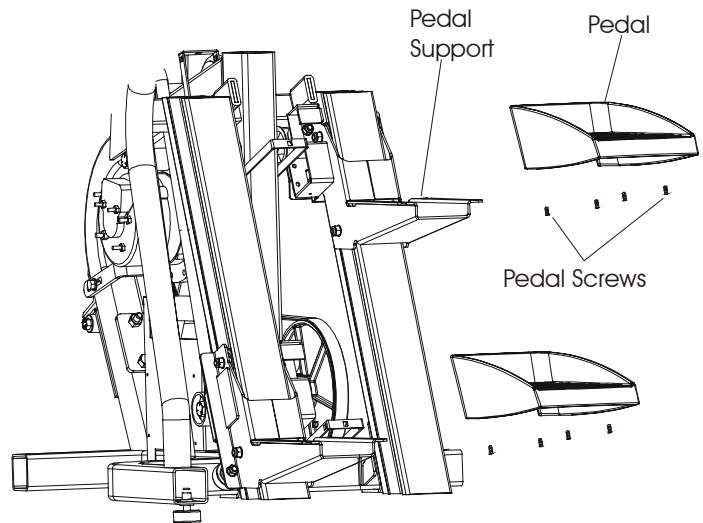

(Pedal Assembly)

1. Remove the side shrouds. See How To...in this section.
2. Disconnect the belt spring assembly at the bottom of the frame and lower the pedals to the floor.
3. Remove the back side idler and upper guide idler. See How To...in this section.
4. Remove the center cover between the pedal assemblies.
5. Remove the pedal track cover and the upper support bracket from the pedal track.
6. Remove the top two bolts from the extrusion, and then loosen the bottom remaining to bolts.
7. With the top of the rail loose, lift the pedal assembly off the rail with the attached belt spring assembly.
8. Remove the belt spring assembly from the pedal assembly. See How To...in this section.
9. Install new pedal assembly in reverse order, and reattach belt spring assembly.

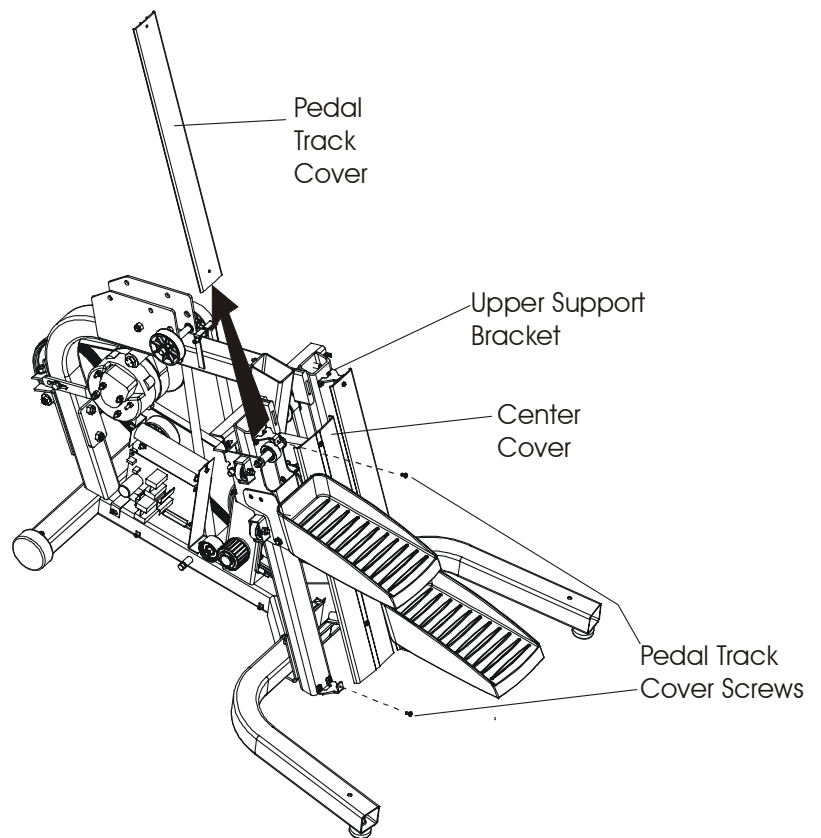

Independent Stairclimbers SC95, SC91, SC85, SC9i, 95Si, 93Si, 90S, and 95Se

How To... Replace Side and Mono Rollers

Special Service Tools: None

Note: For clarity, pedal assembly shown removed.

1. Remove the side shrouds. See How To... in this section.
2. Remove the cover between the pedal assemblies.

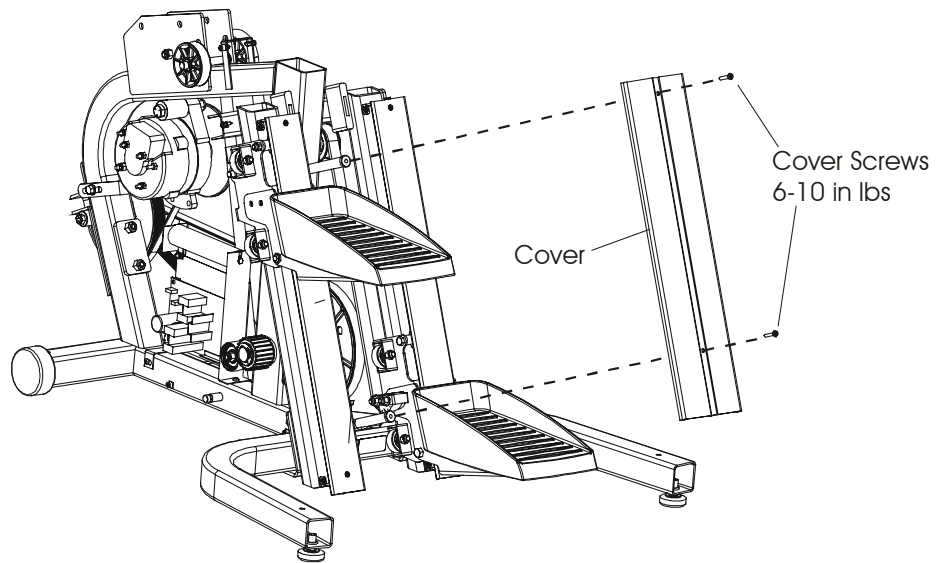

3. Service rollers by simply removing the nut and bolt. There are five side rollers and two mono rollers per pedal assembly. Replace rollers as required.
4. Install new rollers. Need to apply pressure to the top track rollers to ensure that they contact the rail so that the pedal doesn't have too much end play.

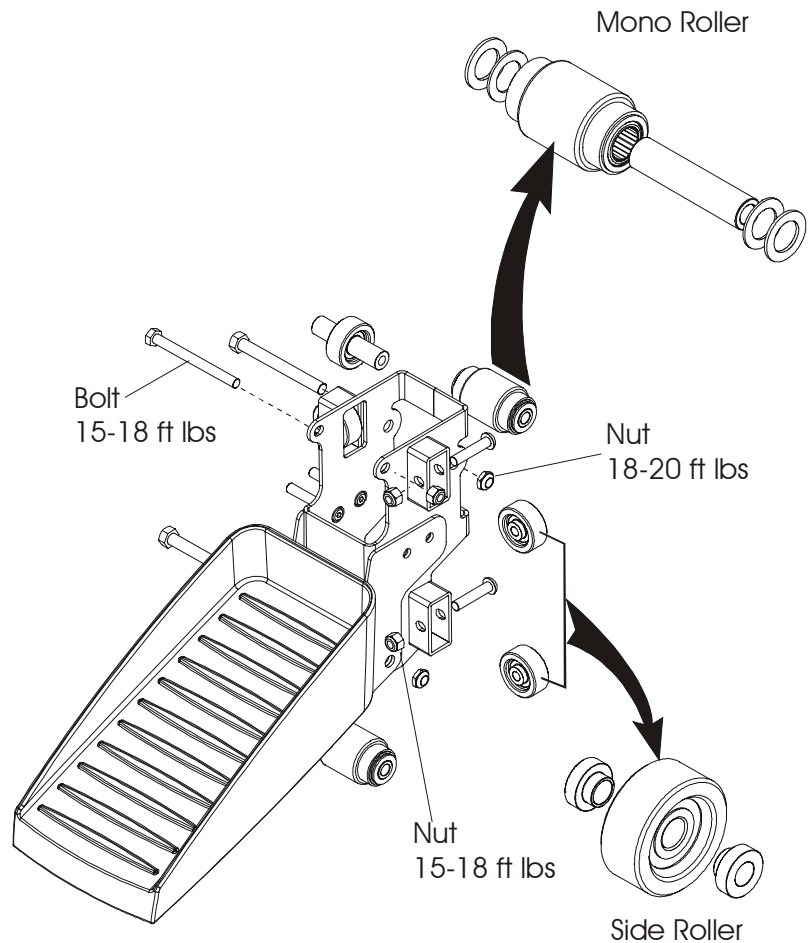

Independent Stairclimbers SC95, SC91, SC85, SC9i, 95Si, 93Si, 90S, and 95Se

How To...Replace the Magnetic Auto Start Reed Switch

Special Service Tools: None

1. Remove the shroud from the right side of the unit. See How To... in this section.
2. Disconnect the magnetic auto start reed switch at terminal P3 on the PCB.
3. Remove the reed switch from the bracket assembly at the front of the unit.
4. Inspect the magnet on the crossover pulley for damage.
5. Facing the front of the bike, loosely install the new reed switch, then move it as far right (away from the magnet) as the slotted hole will allow. Secure reed switch position. The clearance between the face of the magnet and the tip of the reed switch is 0.636 - 0.651".

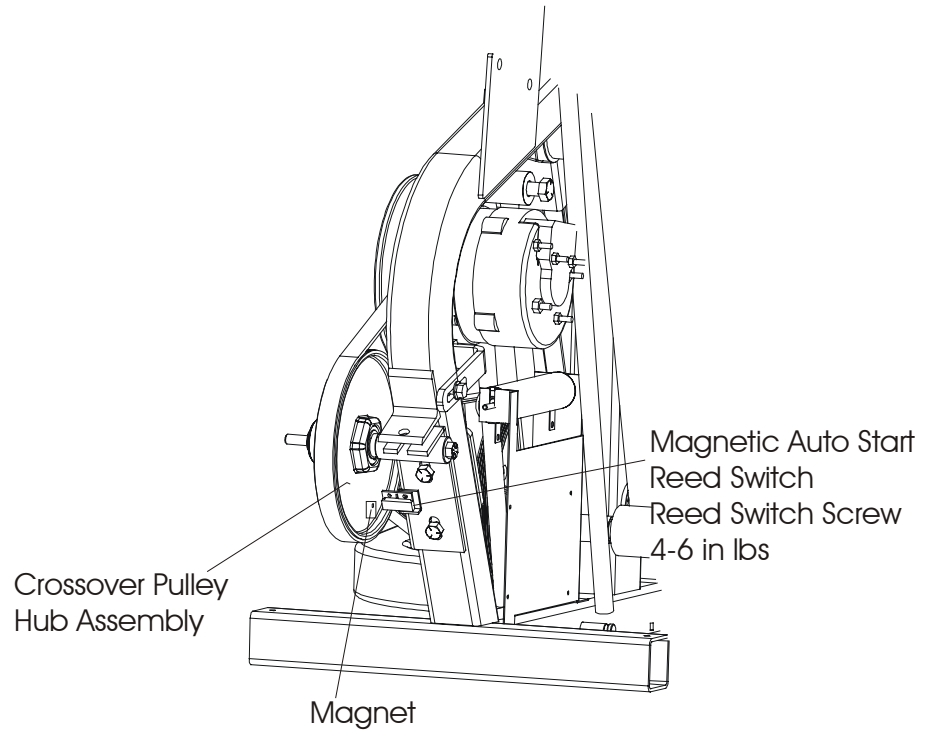

Independent Stairclimbers SC95, SC91, SC85, SC9i, 95Si, 93Si, 90S, and 95Se

How To... Replace the Overlay Bezel

Special Service Tools: None

1. Remove the console and tray assembly from the monocolumn support.
2. Raise the console just enough to disconnect the cable connectors.
3. Remove eight screws securing the front and back console halves together, and then separate.

Note: The Tray mounts to back of the console and does not need to be removed.

4. Remove two ribbon cables (SC9500), or one ribbon cable (SC9100, SC8500, S9i).
5. SC9500 only: remove nine mounting screws securing both circuit boards to the overlay bezel. The communication cable between the two boards does not require removal.
6. SC9100, SC8500, and S9i: remove five mounting screws securing the circuit board to the overlay bezel.
7. Install new overlay bezel in the reverse order.

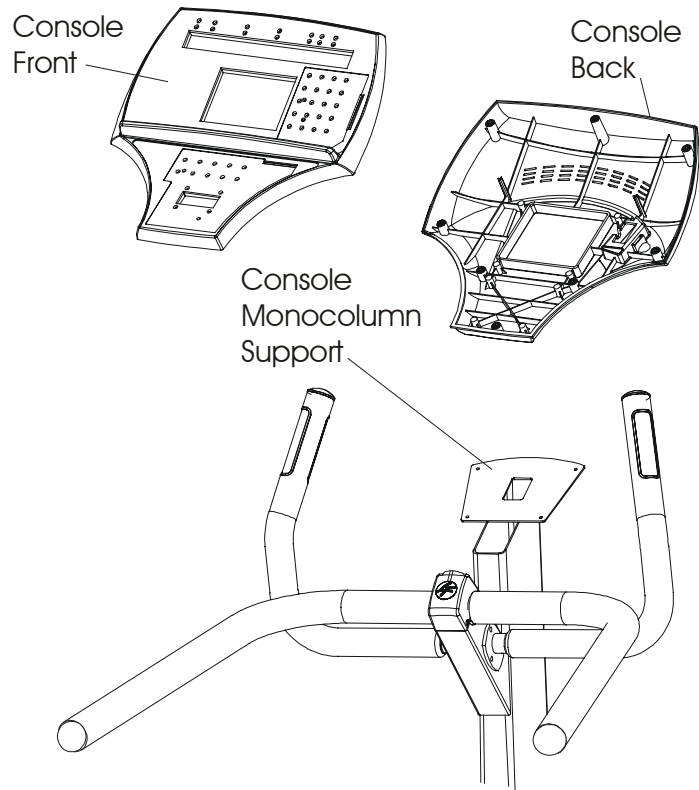

Independent Stairclimbers SC95, SC91, SC85, SC9i, 95Si, 93Si, 90S, and 95Se **How To... Replace the Bullhorns**

Special Service Tools: None

1. Remove the bullhorn mounting screws and carefully separate the bullhorns from the monocolumn just enough to disconnect the heart rate connectors (only SC9500).
2. Install new bullhorns being careful not to pinch or cut wiring.
3. Secure bullhorns in place with mounting bolts.

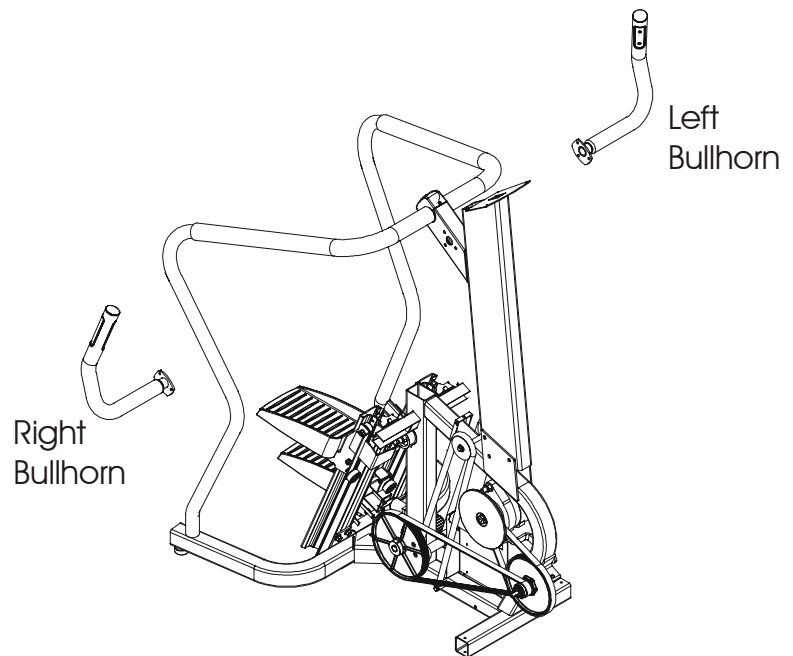

Independent Stairclimbers SC95, SC91, SC85, SC9i, 95Si, 93Si, 90S, and 95Se

How To... Replace the Front Wheel Assembly

Special Service Tools: None

1. Shrouds removed for clarity. Shrouds do not require removal.
2. Remove two screws securing the wheel hub.
3. Pull the wheel assembly out of the frame.
4. Remove the screw and flat washer from the wheel hub assembly, and remove the wheel.
5. Install new wheel and wheel hub assembly in reverse order. CAUTION: Do not over-tighten screws.

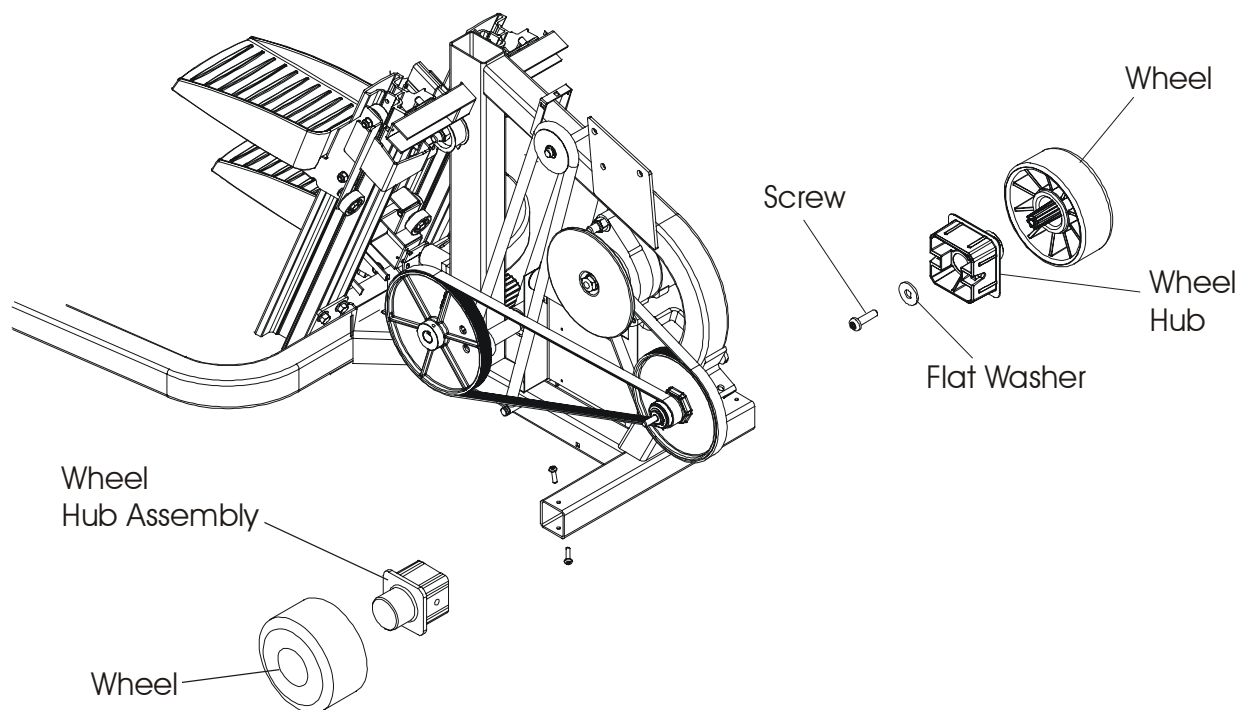

Independent Stairclimbers SC95, SC91, SC85, SC9i, 95Si, 93Si, 90S, and 95Se How To... Replace the Telemetry Receiver

Special Service Tools: None

1. Remove the telemetry receiver cover.
2. Remove the foam protector from the telemetry receiver.
3. Disconnect the telemetry receiver, and then discard.
4. Install new telemetry receiver in reverse order. Make sure to install with indent facing up.

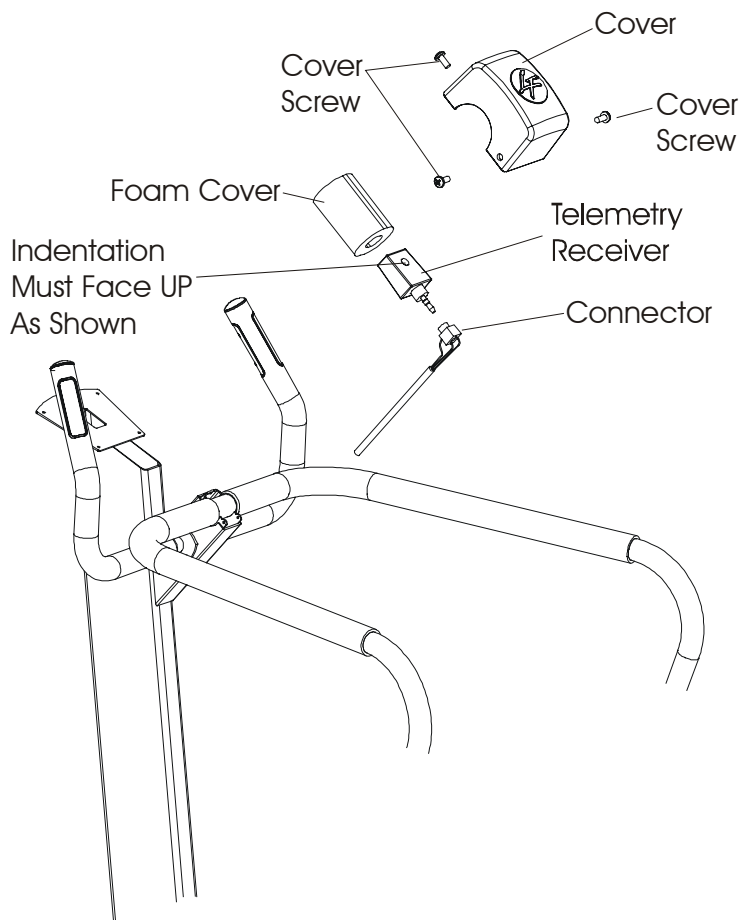

Independent Stairclimbers SC95, SC91, SC85, SC9i, 95Si, 93Si, 90S, and 95Se **How To... Leg Levelers**

Special Service Tools: None

1. Support the rear frame up just enough to remove the leg levelers.
2. Loosen the jam nut.
3. Turn the leg levelers counterclockwise to remove from leg leveler nut.
4. Discard the leg leveler.
5. Install new leg levelers, level the unit by adjusting the leg leveler by turn it in or out.
6. When the unit is level, then tighten the jam nut.

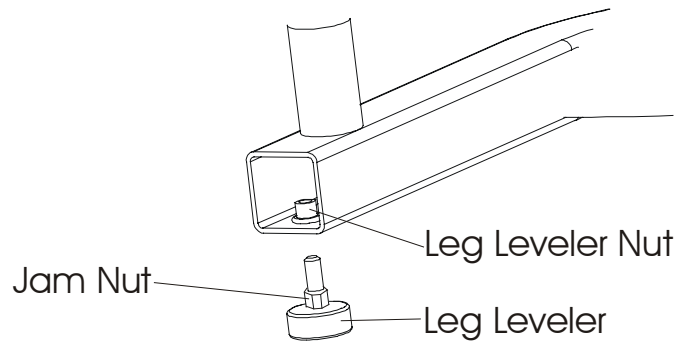

Independent Stairclimbers SC95, SC91, SC85, SC9i, 95Si, 93Si, 90S, and 95Se

How To... Replace the Mono-Column

Special Service Tools: None

1. Remove four screws from the mono-column cover, and then raise it up the column and secure out of the way.
2. Remove the console and tray assembly from the mono-column support.
3. Raise the console enough to disconnect the cable connectors.
4. Remove the bull horns and disconnect Heart Rate Sensor Cable (if equipped).
5. Remove the screws securing the handrail to the mono-column, and then remove the handrail.
6. Remove the polar cover and receiver.
7. Remove the upper handlebars from the vertical handlebars.
8. Remove the top (2) bolts that secures the mono-column to the frame.
9. Loosen the third lower bolt and leave it in the frame.

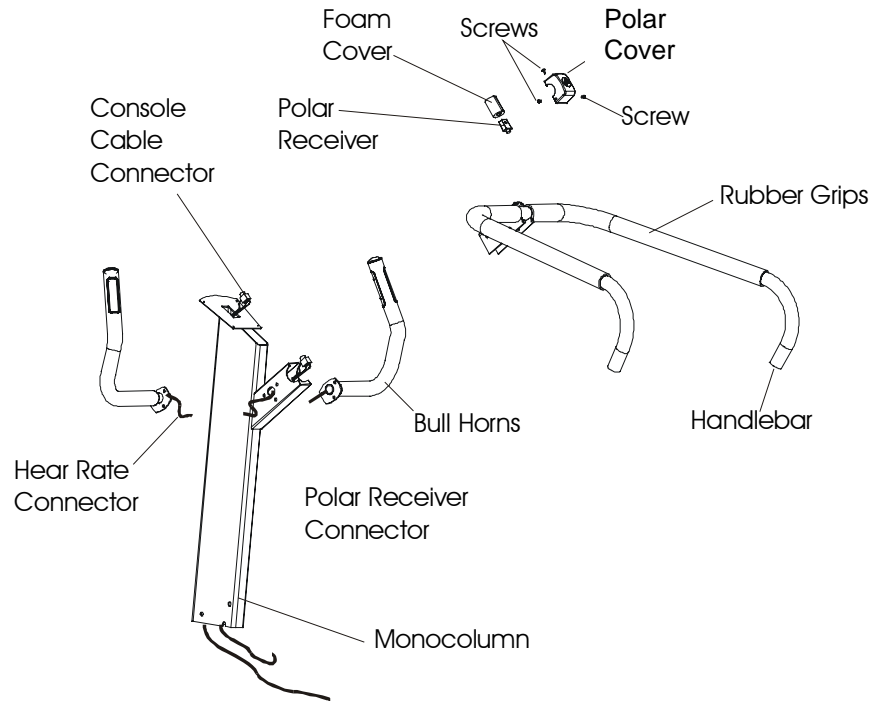

- Note: When installing the new mono-column, the notch in the bottom of the mono-column will be placed over this bolt to help locate the mono-column in the frame.
10. Remove the cable(s) from the mono-column.
 11. Place the mono-column shroud over the new mono-column, being careful not to damage the cable and connectors.
 12. Install the new mono-column in reverse order.

Independent Stairclimbers SC95, SC91, SC85, SC9i, 95Si, 93Si, 90S, and 95Se How To... Replace the Power Control Board (PCB)

Special Service Tools: None

1. Remove the left side shroud. See How To... in this section.
2. Disconnect the wiring connectors from the PCB.
3. Remove four Phillips screws from the board, and then remove the board. If necessary, replace the four plastic grommets in the mounting bracket.
4. Install new board in reverse order of removal. Make sure to that connectors are seated in their terminals.

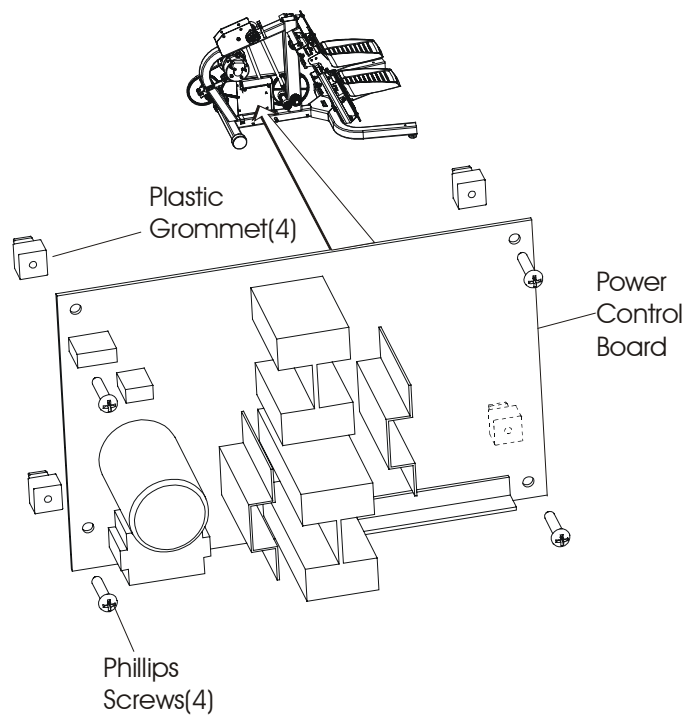

Independent Stairclimbers SC95, SC91, SC85, SC9i, 95Si, 93Si, 90S, and 95Se

How To... Replace the Resistor Assembly

Special Service Tools: None

1. Remove the left side shroud. See How To... in this section.
2. Disconnect wiring from the resistor terminals.
3. Loosen the resistor mounting screw and nut.
4. Lift out the resistor from the slotted grooves in the mounting bracket.

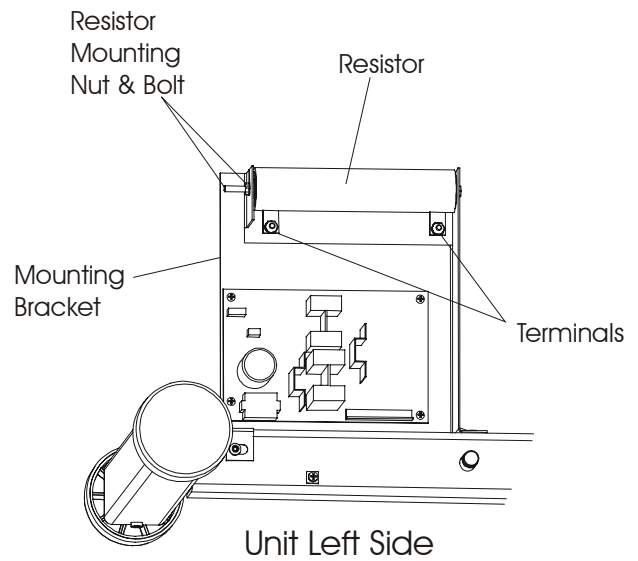

5. Assemble new resistor parts.
6. Install new resistor in reverse order.

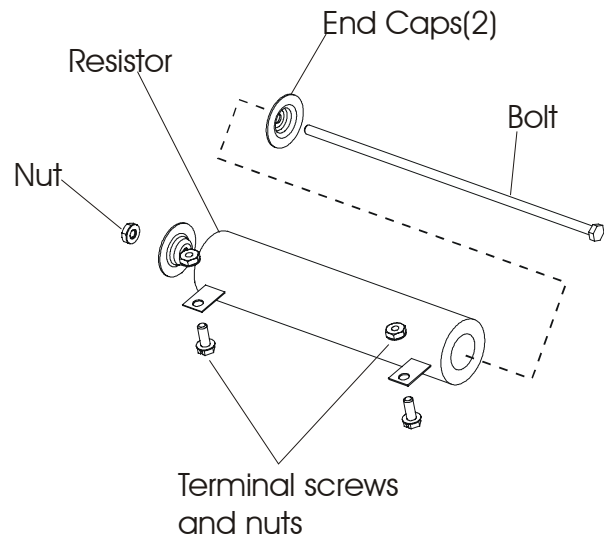

Life Fitness Independent Stairclimbers S9i, SC9500HR, SC9100, SC8500

How To... Replace the Return Springs

1. Remove four screws securing the mono-column shroud.
2. Lift the mono-column shroud up the mono-column and secure it up out of the way.
3. Remove six screws securing the left shroud. Carefully pull the left shroud back just enough to reach in and disconnect the power jack lead wire from the PCB Board.
4. Remove the right shroud.

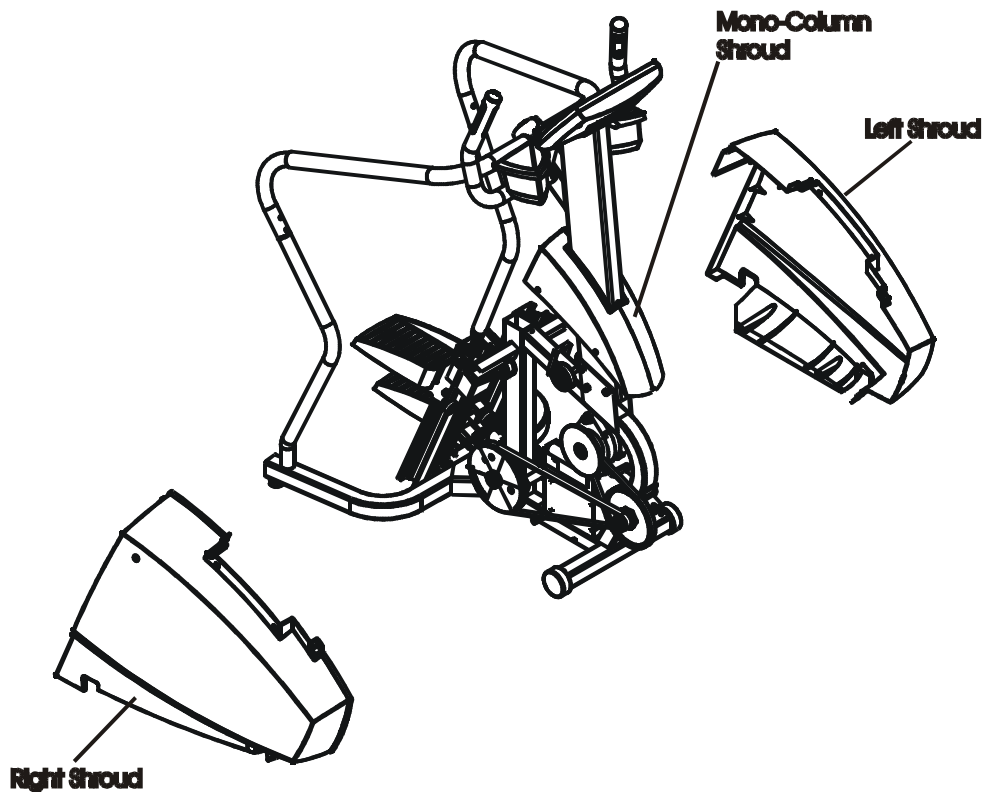
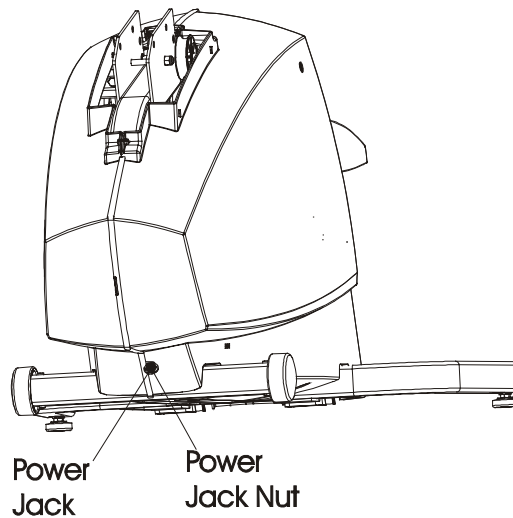

Life Fitness Independent Stairclimbers S9i, SC9500HR, SC9100, SC8500

How To... Replace the Return Springs

5. Disconnect the return spring at the bottom of the frame, and lower the pedal to the floor.
6. Carefully guide the Timing Belt off of the top of the Clutch.
7. Disconnect the screw and nut securing the Securing the retainer brackets, Timing belt, and return spring.
8. Install the New springs in the reverse order ensuring the positions of the retainer brackets, Timing belt, and return spring match the illustration below.
9. Install new covers in reverse order. Before installing the left shroud, reconnect the power jack to the PCB Board, and then secure side shrouds. Do Not over-tighten shroud screws.

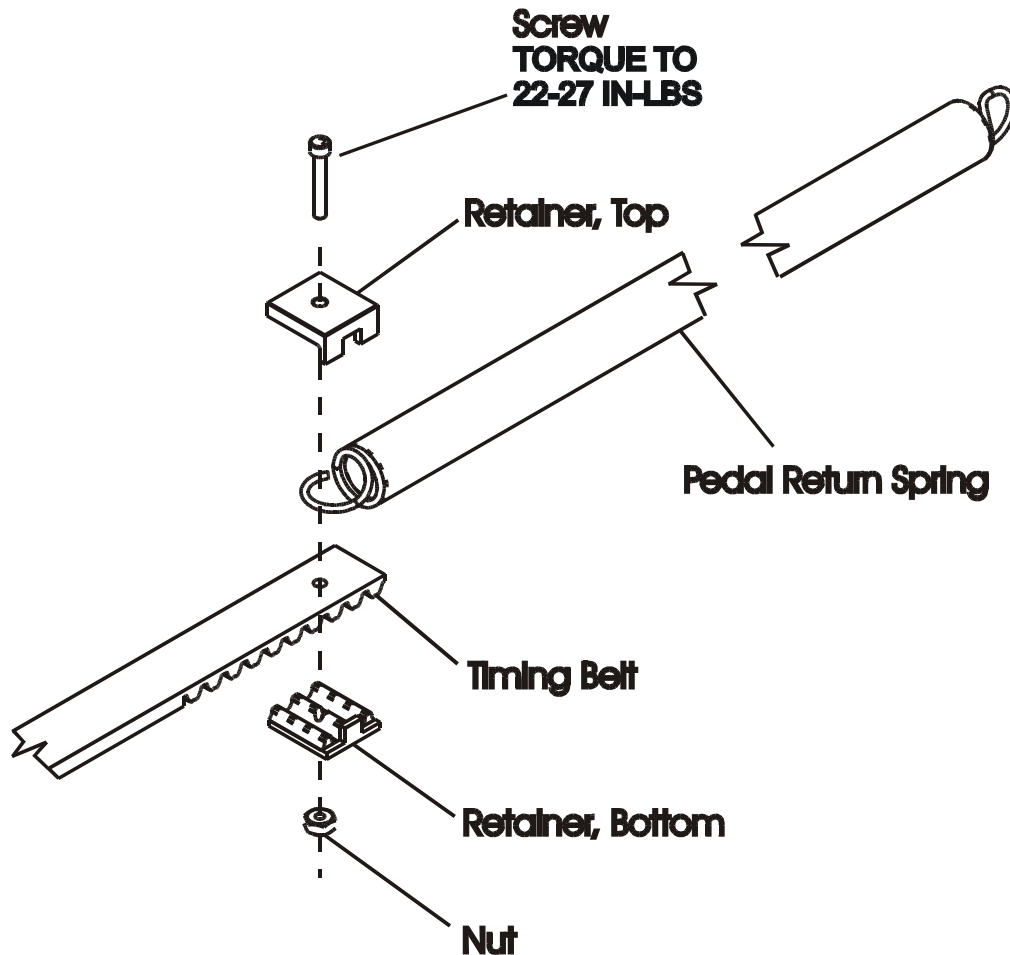
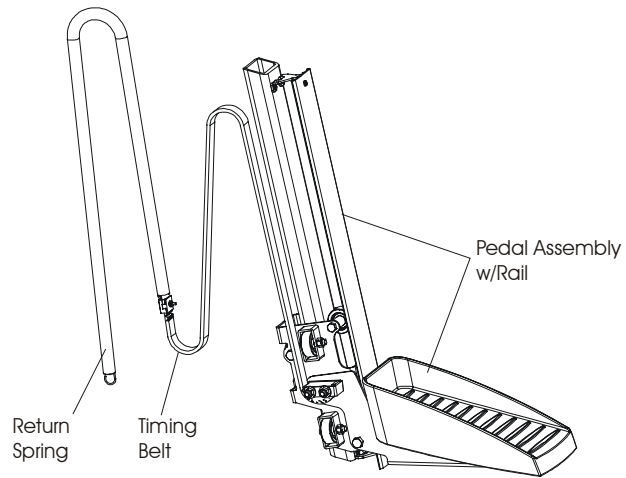

Independent Stairclimbers SC95, SC91, SC85, SC9i, 95Si, 93Si, 90S, and 95Se LCD Integrated Console Service Overview

Special Service Tools Required: NONE

CAUTION! BEFORE REPLACING CIRCUIT BOARD(S), GROUND YOURSELF TO EARTH GROUND USING AN ANTI-STATIC GROUND STRAP.

NOTE: The following pages provide service procedures for servicing the LCD Integrated Console. While the Console Housings may differ between the various products, the internal components, which make up the Console, are identical. Use the exploded view below to help identify parts and component location during service.

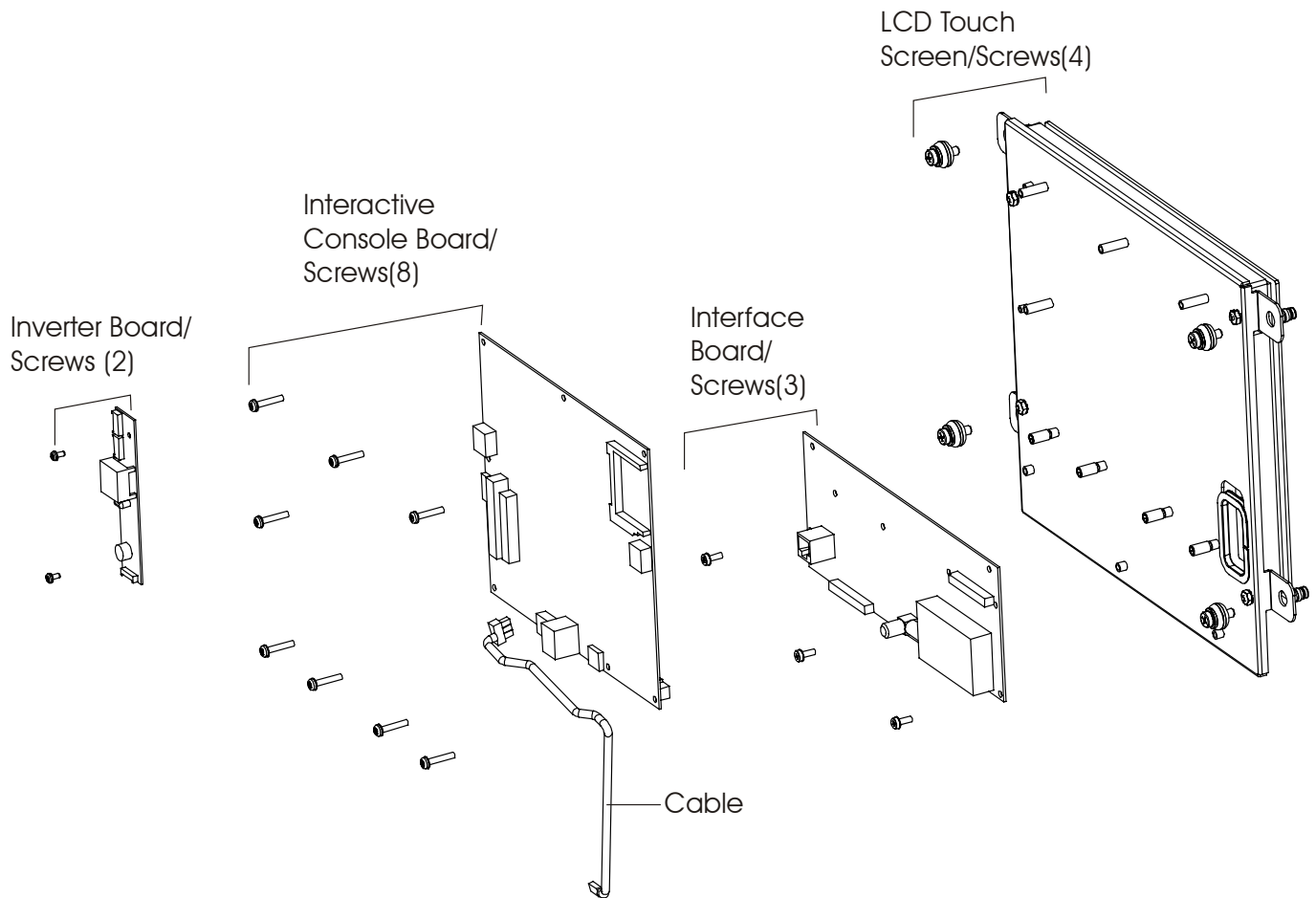

Independent Stairclimbers SC95, SC91, SC85, SC9i, 95Si, 93Si, 90S, and 95Se How To... Replace the Headphone Jack

Special Service Tools Required: NONE

**CAUTION! BEFORE REPLACING CIRCUIT BOARD(S),
GROUND YOURSELF TO EARTH GROUND USING AN
ANTI-STATIC GROUND STRAP.**

Note: For clarity purposes the Console is shown off the unit. Headphone Jack replacement does not require removal of the Console from the unit.

1. At the bottom of the Console, remove the Phillip Screw securing the Headphone Jack.
2. Remove the Headphone Jack from the Console.
3. Install new Headphone Jack in reverse order.

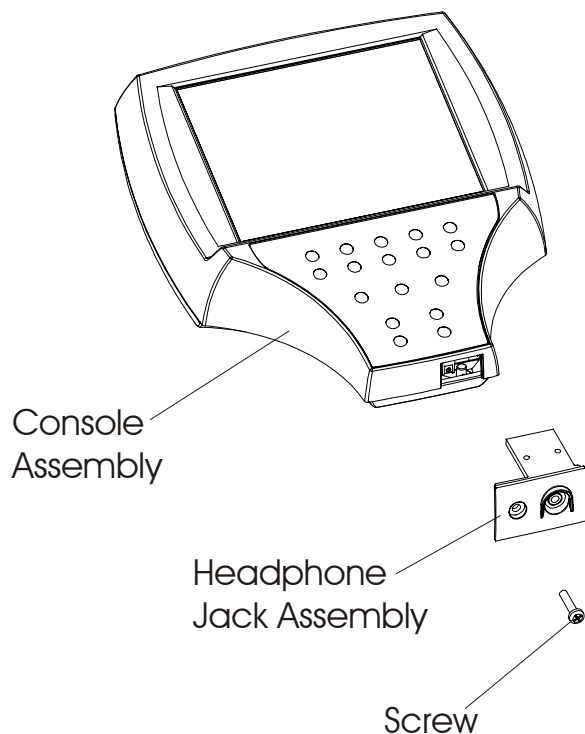

Independent Stairclimbers SC95, SC91, SC85, SC9i, 95Si, 93Si, 90S, and 95Se

How To... Replace the Inverter Board

Special Service Tools Required: NONE

CAUTION! BEFORE REPLACING CIRCUIT BOARD(S), GROUND YOURSELF TO EARTH GROUND USING AN ANTI-STATIC GROUND STRAP.

1. Remove console form unit refer to Display Console and Accessory Tray Removal.
2. Remove seven screws from the Back Cover and lift the Back Cover off.

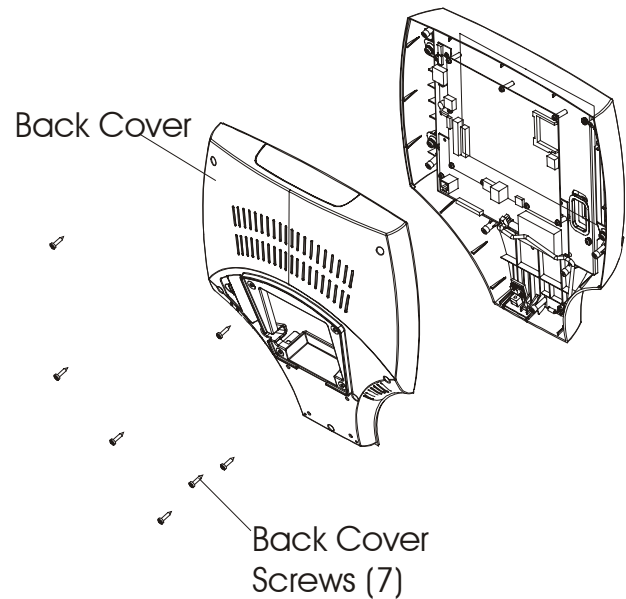

3. Disconnect the Pink/White Power Wire Connectors (2) from the top of the Inverter Board, and the 4-Yellow Wires Connector, which receives Power from the PC to the Inverter, at the bottom of the Inverter Board.
4. Remove two Phillips screws securing the Inverter Board to the back of the LCD Touch Screen and lift it out.
5. Install new Inverter Board in reverse order.

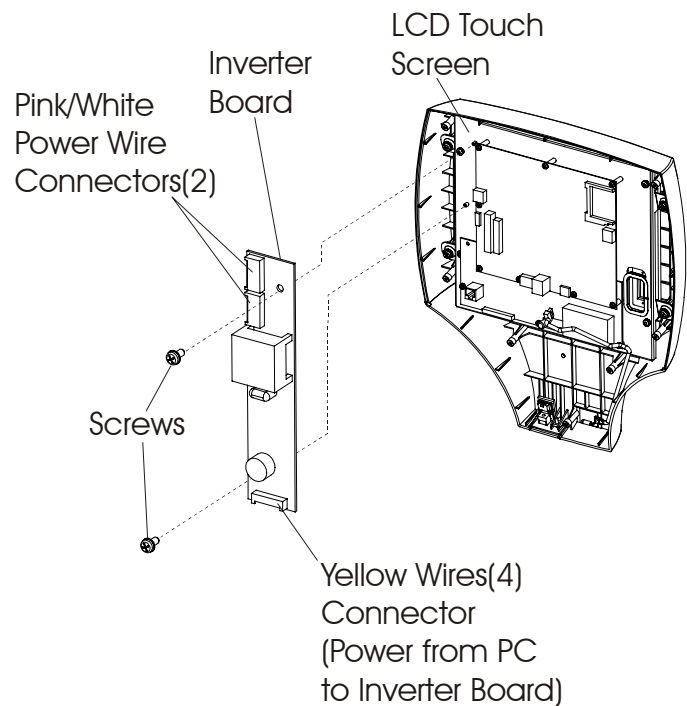

Independent Stairclimbers SC95, SC91, SC85, SC9i, 95Si, 93Si, 90S, and 95Se

How To... Replace the Single Board Computer

Special Service Tools Required: NONE

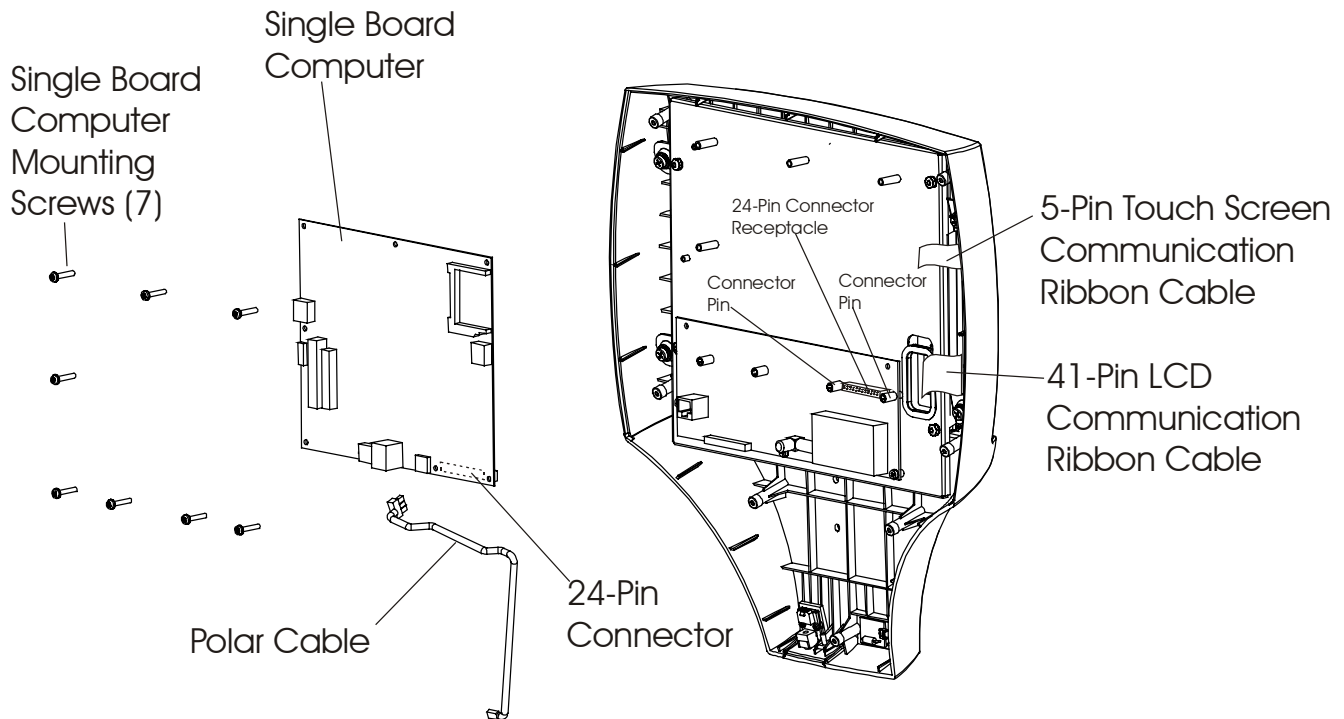

CAUTION! BEFORE REPLACING CIRCUIT BOARD(S), GROUND YOURSELF TO EARTH GROUND USING AN ANTI-STATIC GROUND STRAP.

1. Remove console form unit refer to Display Console and Accessory Tray Removal.
2. Remove seven screws from the Back Cover.
3. Disconnect all of the cables from the Single Board Computer.
4. Remove seven screws securing the Single Board Computer to the back of the LCD Touch Screen. The Single Board Computer remains engaged into a 24-Pin Connector Receptacle, which is located between two Connector Pins on the Interface Board. Carefully wiggle the Single Board Computer up and out of the Interface Board Connector Receptacle and Connector Pins.
5. Install Board in reverse order. Been careful on connecting the single board computer to the machine interface board.

Independent Stairclimbers SC95, SC91, SC85, SC9i, 95Si, 93Si, 90S, and 95Se How To... Replace the Interface Board

Special Service Tools Required: NONE

CAUTION! BEFORE REPLACING CIRCUIT BOARD(S), GROUND YOURSELF TO EARTH GROUND USING AN ANTI-STATIC GROUND STRAP.

1. Remove console form unit refer to Display Console and Accessory Tray Removal.
2. Remove seven screws from the Back Cover.
3. Remove Single Board Computer
4. Disconnect all Cables from the interface board.
5. Remove 5 screws securing the Interface Board to the mounting bracket.
6. Remove the Interface Board.
7. Install board in reverse order. Been careful on connecting the single board computer to the machine interface board.

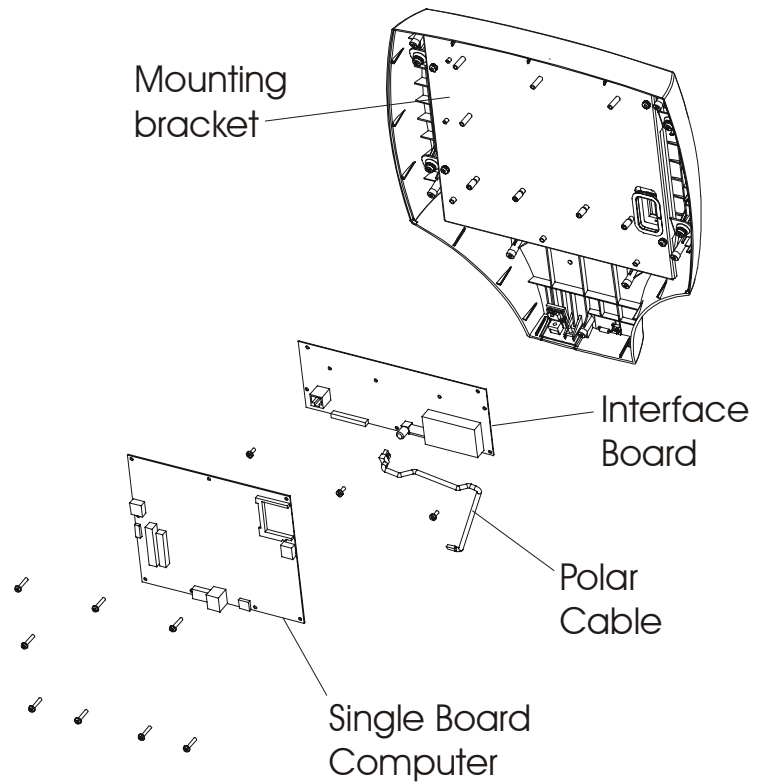

Independent Stairclimbers SC95, SC91, SC85, SC9i, 95Si, 93Si, 90S, and 95Se

How To... Replace the Touch Screen Assembly

Special Service Tools Required: NONE

CAUTION! BEFORE REPLACING CIRCUIT BOARD(S), GROUND YOURSELF TO EARTH GROUND USING AN ANTI-STATIC GROUND STRAP.

1. Remove console form unit refer to Display Console and Accessory Tray Removal.
2. Remove seven screws from the Back Cover.
3. Remove the Single Board Computer. See "How To Replace the Single Board Computer" in this section.
4. Remove the Interface Board. See "How To Replace the Interface Board" in this section.
5. **Remove the Inverter Board. See "How To Replace the Inverter Board" in this section**
6. Remove four screws securing the Touch Screen Bracket Assembly to the bezel Assembly. Remove the Touch Screen Assembly from the Console.
7. Remove the four nuts securing the LCD/touch screen to the bracket then separate the bracket from the assembly.
8. Install new Touch Screen in reverse order.

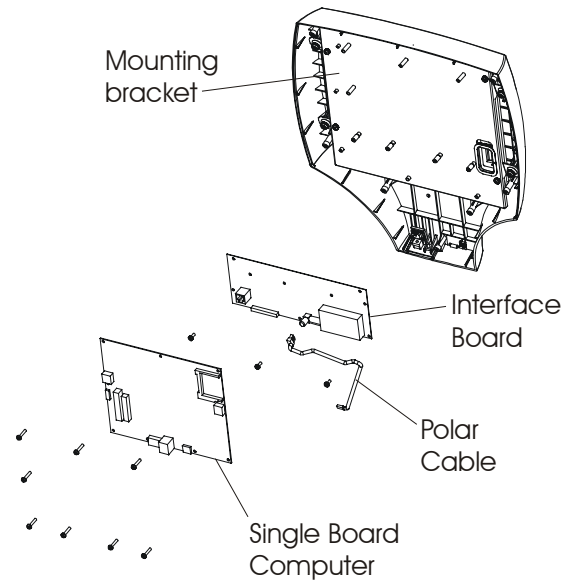
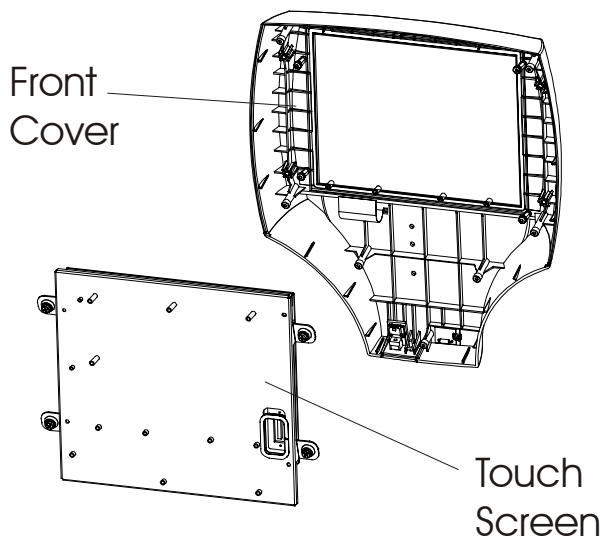
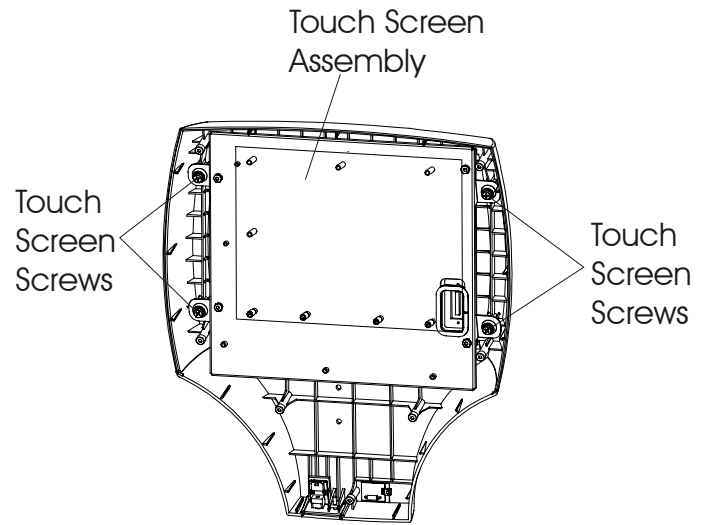

Independent Stairclimbers SC95, SC91, SC85, SC9i, 95Si, 93Si, 90S, and 95Se

Notes

SECTION IV

ELECTRONICS AND WIRING DIAGRAMS

	Page
Display Console Board - Model SC95 and 95Si.....	3
Display Console Board - Model SC91, 95Si, SC85, 90S, and S9i.....	7
Alternator Control Board	10
Alternator.....	11
Wiring Block Diagram Model SC95 and 95Si.....	12
Wiring Block Diagram Model SC91, 95Si, SC85, and 90S	13
Wiring Block Diagram S9i.....	14

Independent Stairclimbers SC95, SC91, SC85, S9i, 95Si, 93Si, 90S, and 95Se

Notes

**Independent Stairclimbers SC95, SC91, SC85, S9i, 95Si, 93Si, 90S, and 95Se
DISPLAY CONSOLE BOARD - Model SC95 and 95Si**

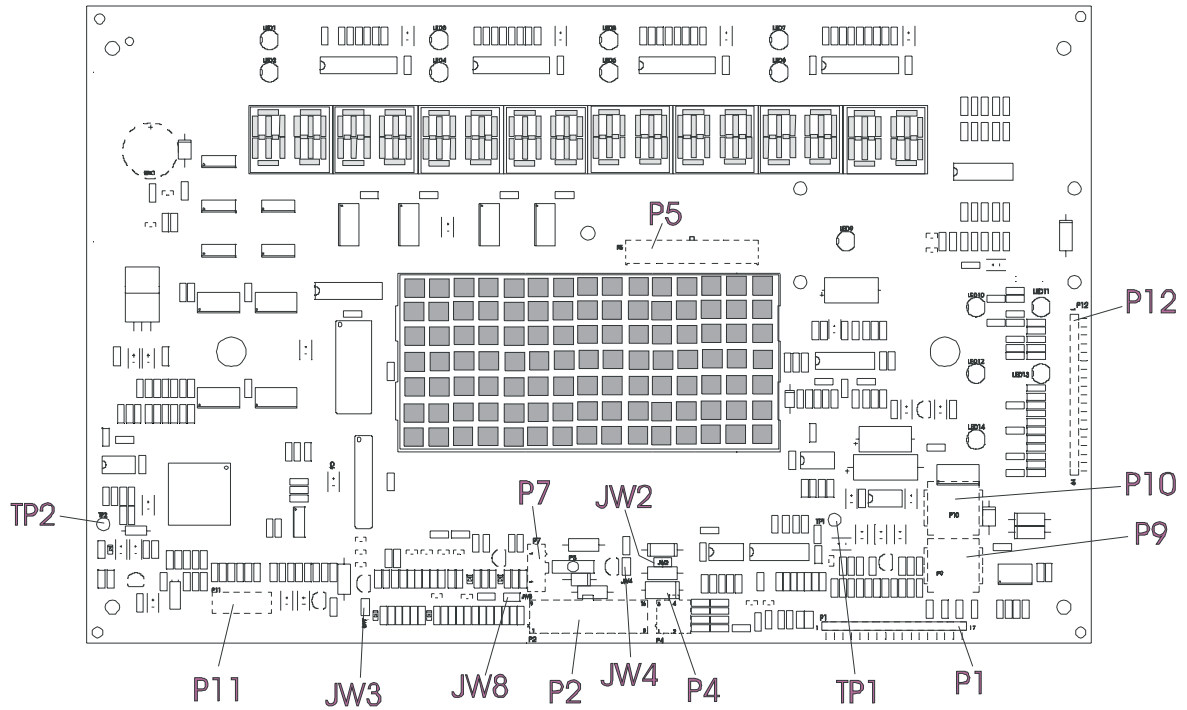

Functional Description



The Display Console Board is designed to work in conjunction with the Alternator Control Board. It reads the keypad input for changes or updates by the user, and refreshes the status LEDs, data display, and profile display matrix.

Connector and Pin Descriptions

Connector	Location	Pin	Functional Description
P2 is a 16 pin connector at the console and connects at P1 of the control board.		1	NOT USED
		2	GND (NOT USED)
		3	VSYS (NOT USED)
		4	VBAT
		5	RPM REED
		6	RPM ALT
		7	A_START
		8	VALT
		9	RELAY (NOT USED)
		10	GND (NOT USED)
		11	GND
		12	VBAT
		13	FIELD-KICK (Reed Control)
		14	FIELD
		15	LOAD-CMD
		16	VSYS

**Independent Stairclimbers SC95, SC91, SC85, S9i, 95Si, 93Si, 90S, and 95Se
DISPLAY CONSOLE BOARD - Model SC95 and 95Si**

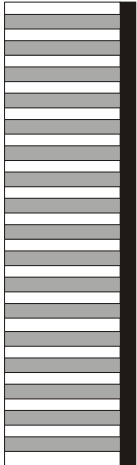
Connector and Pin Descriptions





Connector	Location	Pin	Functional Description
P1 is a 17 pin ribbon connector that connects to the lower keypad switch membrane.		1	Ground
		2	Return
		3	Strobe
		4	Return
		5	Return
		6	Strobe
		7	Return
		8	Strobe
		9	Return
		10	Strobe
		11	Return
		12	Strobe
		13	Return
		14	Strobe
		15	Start
		16	Ground
		17	Ground
P12 is a 19 pin ribbon connector that connects to the upper keypad switch membrane.		1	Ground
		2	Strobe
		3	Return
		4	Strobe
		5	Strobe
		6	Return
		7	Strobe
		8	Return
		9	Strobe
		10	Return
		11	Return
		12	Strobe
		13	Return
		14	Strobe
		15	Start
		16	Ground
		17	Return
		18	Strobe
		19	Ground

**Independent Stairclimbers SC95, SC91, SC85, S9i, 95Si, 93Si, 90S, and 95Se
 DISPLAY CONSOLE BOARD - Model SC95 and 95Si**

Connector	Location	Pin	Functional Description																								
P5 is a 24 pin connector that connects to the lower console display board. ALL TERMINAL PINS ARE FOR TIME DISPLAY REFERENCE ONLY	<table border="1" style="border-collapse: collapse; text-align: center; width: 100%;"> <tr><td>24</td><td>1</td></tr> <tr><td>23</td><td>2</td></tr> <tr><td>22</td><td>3</td></tr> <tr><td>21</td><td>4</td></tr> <tr><td>20</td><td>5</td></tr> <tr><td>19</td><td>6</td></tr> <tr><td>18</td><td>7</td></tr> <tr><td>17</td><td>8</td></tr> <tr><td>16</td><td>9</td></tr> <tr><td>15</td><td>10</td></tr> <tr><td>14</td><td>11</td></tr> <tr><td>13</td><td>12</td></tr> </table>	24	1	23	2	22	3	21	4	20	5	19	6	18	7	17	8	16	9	15	10	14	11	13	12	1	Strobe
		24	1																								
		23	2																								
		22	3																								
		21	4																								
		20	5																								
		19	6																								
		18	7																								
		17	8																								
		16	9																								
		15	10																								
		14	11																								
		13	12																								
		2	Strobe																								
		3	Strobe																								
		4	Strobe																								
		5	Strobe																								
		6	Strobe																								
		7	Strobe																								
		8	Lower Console Detect																								
		9	D0																								
		10	D1																								
		11	D2																								
		12	D3																								
13	D4																										
14	D5																										
15	D6																										
16	D7																										
17	D8																										
18	D9																										
19	D10																										
20	D11																										
21	D12																										
22	D13																										
23	D14																										
24	DI5																										

**Independent Stairclimbers SC95, SC91, SC85, S9i, 95Si, 93Si, 90S, and 95Se
DISPLAY CONSOLE BOARD - Model SC95 and 95Si**

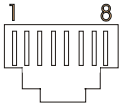
Connector and Pin Descriptions

Connector	Location	Pin	Functional Description
P4 is a 4 pin connector that connects to the heart rate sensor.		1	LEFT – GND
		2	RIGHT – GND
		3	LEFT + SIGNAL
		4	RIGHT + SIGNAL
P7 is a 3 pin connector that connects to the polar signal.		1	+VCC (5VDC)
		2	POLAR SIGNAL
		3	GND
P9 and P10 are 8 pin connectors that connect to the CSAFE and Cardio Theater or broadcast vision interface.		1	N/U - not used
		2	N/U - not used
		3	Receive Data
		4	Transmit Data
		5	V CARDIO
		6	CTS
		7	Ground
		8	VSYSC
P11 is a 10 pin connector that connects to the background debug mode signals.		1	DS
		2	BERR
		3	Ground
		4	BKPT
		5	GND
		6	FREEZE
		7	RESET
		8	DSI
		9	VCC
		10	DS0

**Independent Stairclimbers SC95, SC91, SC85, S9i, 95Si, 93Si, 90S, and 95Se
 DISPLAY CONSOLE BOARD - Models SC91, 95Si, SC85, 90S, and S9i**

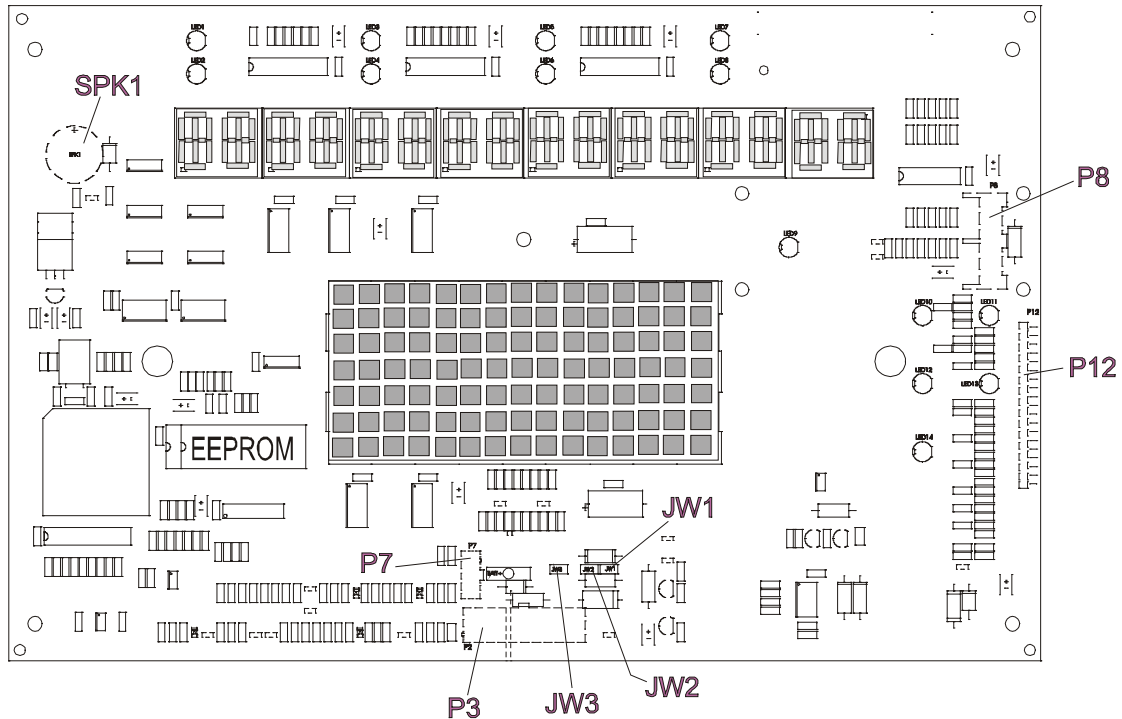

Functional Description



The Display Console Board is designed to work in conjunction with the Alternator Control Board. It reads the keypad input for changes or updates by the user, and refreshes the status LEDs, data display, and profile display matrix.

Connector and Pin Descriptions

Connector	Location	Pin	Functional Description
P2 is a 16 pin connect that connects to the display control board.		1	N.C.
		2	GND (NOT USED)
		3	VSYS (NOT USED)
		4	VBAT
		5	RPM REED
		6	RPM ALT
		7	ASTART
		8	VALT.
		9	RELAY (NOT USED)
		10	GND (NOT USED)
		11	GND
		12	VBAT
		13	FIELD-KICK (Reed Control)
		14	FIELD
		15	LOAD-CMD
		16	VSYS

**Independent Stairclimbers SC95, SC91, SC85, S9i, 95Si, 93Si, 90S, and 95Se
 DISPLAY CONSOLE BOARD - Models SC91, 95Si, SC85, 90S, and S9i**

Connector and Pin Descriptions

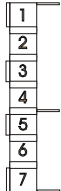
Connector	Location	Pin	Functional Description
P12 is a 19 pin ribbon connector that connects to the upper keypad switch membrane.		1	Ground
		2	Strobe
		3	Return
		4	Strobe
		5	Strobe
		6	Return
		7	Strobe
		8	Return
		9	Strobe
		10	Return
		11	Return
		12	Strobe
		13	Return
		14	Strobe
		15	Start
		16	Ground
		17	Return
		18	Strobe
		19	Ground
P7 is a 3 pin connector that connects to the polar signal.		1	+VCC (5VDC)
		2	POLAR SIGNAL
		3	GROUND
P8 is an 7 pin connector that connects to the CSAFE card.		1	GND
		2	KEY
		3	TDO
		4	RDI
		5	CTS
		6	VCC
		7	V CARDIO

Independent Stairclimbers SC95, SC91, SC85, S9i, 95Si, 93Si, 90S, and 95Se

ALTERNATOR CONTROL BOARD

Functional Description

The Alternator Control Board is designed to regulate the alternator voltage by modulating the field current. It regulates the pass current (RPM signal) from the Alternator to the Console, and the pass current from the alternator to the load resistor while providing supply voltage for the console while charging the system battery.

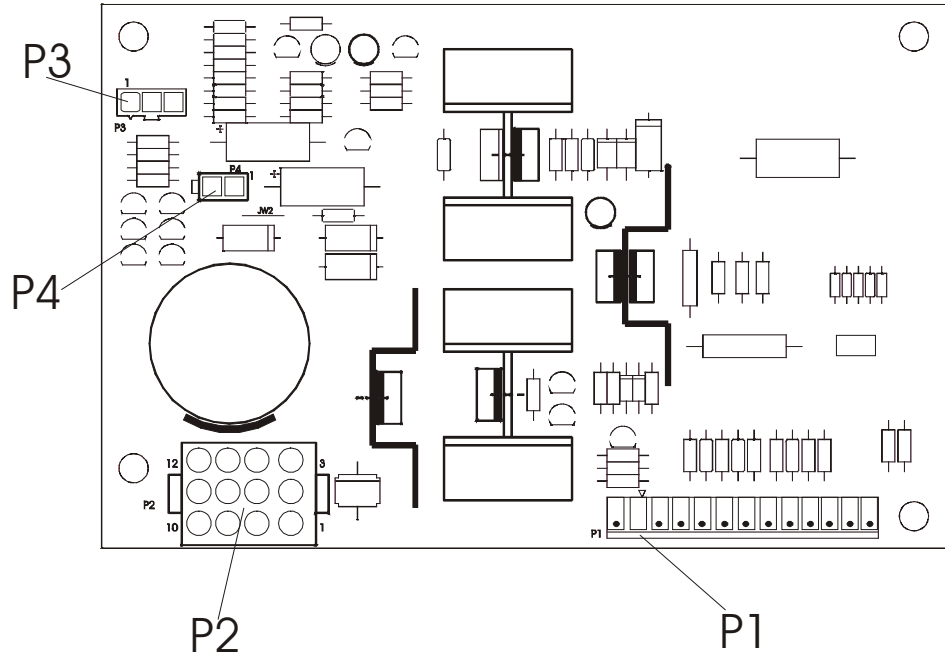

Connector and Pin Connections

Connector	Location	Pin	Functional Description
P1 is a 13 pin connector that connects to the console.		1	A START
		2	KEY (NO PIN)
		3	NOT USED
		4	VSYS (7-8VDC)
		5	LOAD DMD
		6	FIELD
		7	RPM (0-15 V)
		8	REED RPM
		9	VALT (7-15V)
		10	REED CONTROL
		11	VBAT (6VDC)
		12	GROUND - BATTERY
		13	GROUND
P2 is a 12 pin connector that connects to the alternator and power resistor		1	GROUND – ALTERNATOR
		2	GROUND – ALTERNATOR
		3	GROUND – ALTERNATOR
		4	RPM (0-15V)
		5	GROUND – FIELD
		6	FIELD (1-4 VDC)
		7	LOAD
		8	LOAD (NOT USED)
		9	LOAD
		10	VALT (7-15V)
		11	VALT (NOT USED)
		12	LOAD

Independent Stairclimbers SC95, SC91, SC85, S9i, 95Si, 93Si, 90S, and 95Se
ALTERNATOR CONTROL BOARD

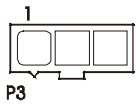
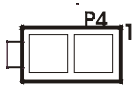
Connector	Location	Pin	Functional Description
P3 is a 3 pin connector that connect to the reed Switch		1	GND
		2	Vbat
		3	RPM-REED
P4 is a 2 Pin connector that provides external power (LC95 only).		1	9 Volt
		2	GND

Independent Stairclimbers SC95, SC91, SC85, S9i, 95Si, 93Si, 90S, and 95Se ALTERNATOR

Functional Description

The 12 volt, 35 amp Alternator is designed to provide electrical power to the product, supply load resistance while providing electrical power, and provide the RPM signal from the AC TAP to the Alternator Control Board.

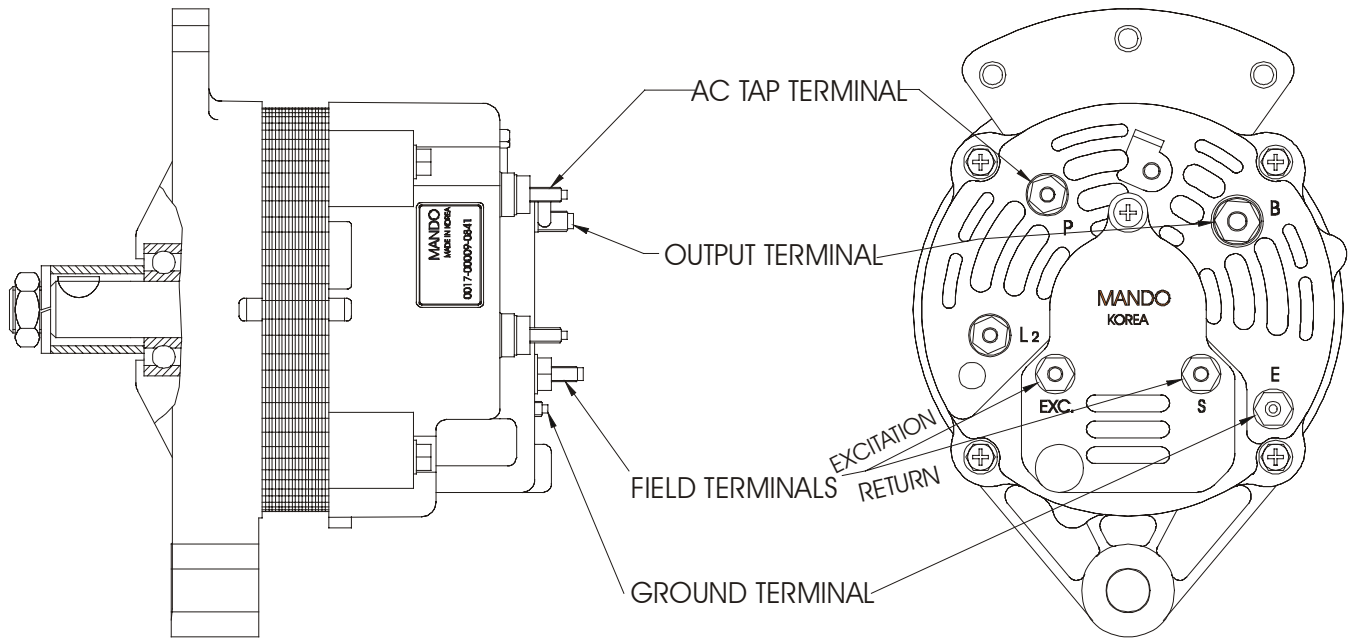

Independent Stairclimbers SC95, SC91, SC85, S9i, 95Si, 93Si, 90S, and 95Se WIRING BLOCK DIAGRAM – Model SC95 and 95Si

Power Control to Alternator Board (PCB) Cable

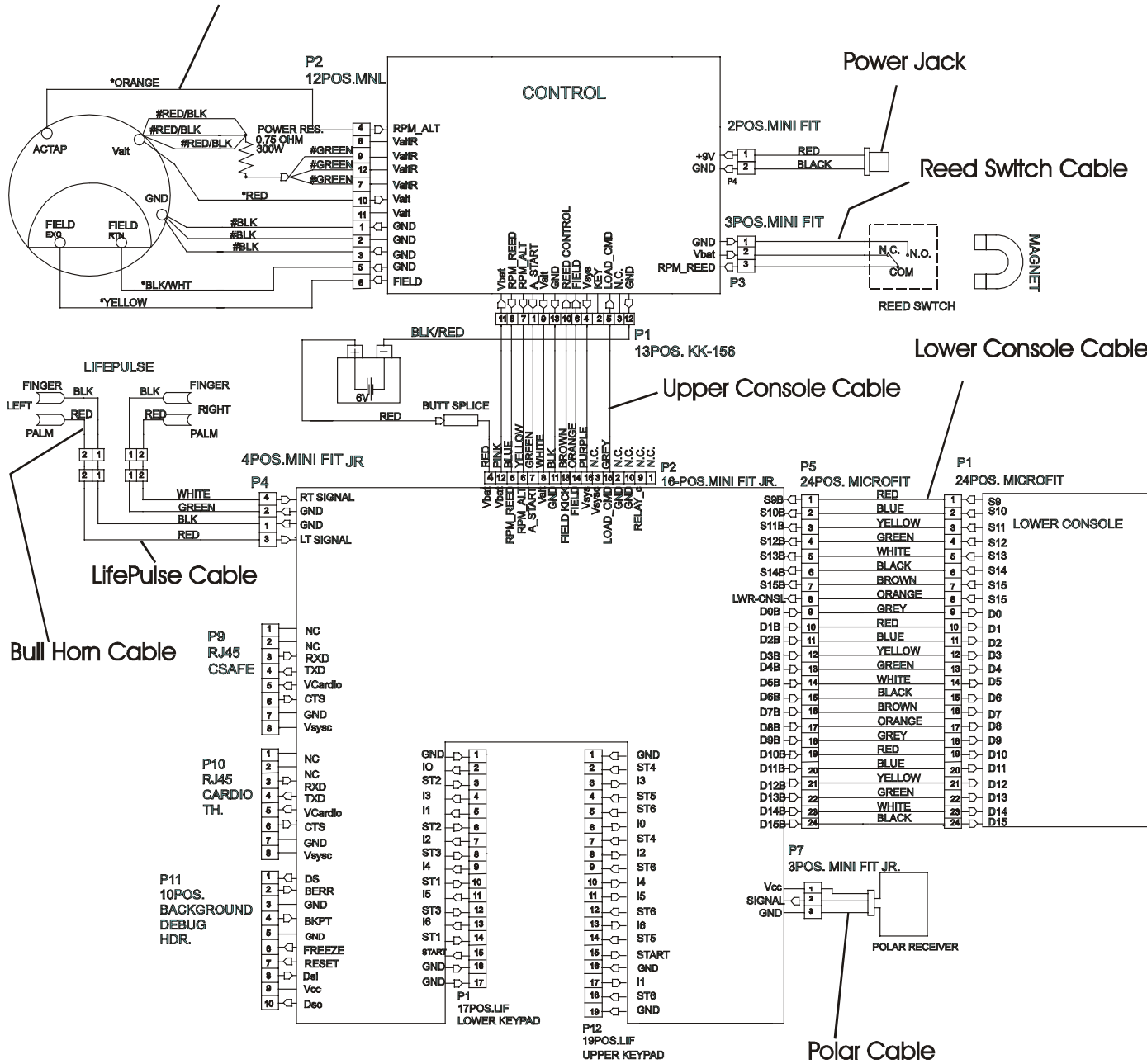

Independent Stairclimbers SC95, SC91, SC85, S9i, 95Si, 93Si, 90S, and 95Se WIRING BLOCK DIAGRAM - Model S9i

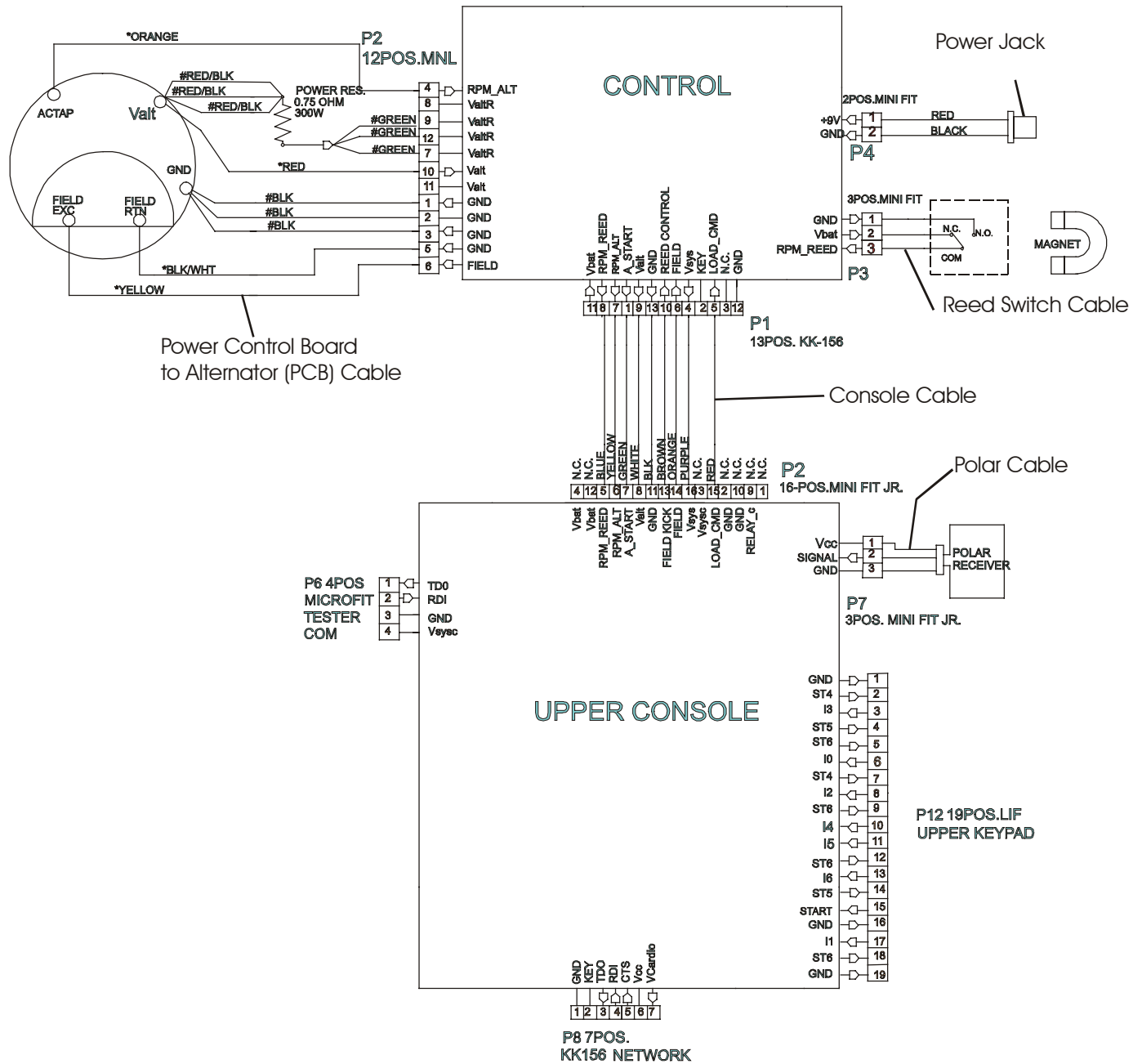

SECTION V

MISCELLANEOUS

	Page
Model Identification and Serial Number Location.....	3
Preventative Maintenance Tips and Safety Instructions	4
Notes.....	5

Independent Stairclimbers SC95, SC91, SC85, S9i, 95Si, 93Si, 90S, and 95Se

Notes

MODEL IDENTIFICATION and SERIAL NUMBER LOCATION

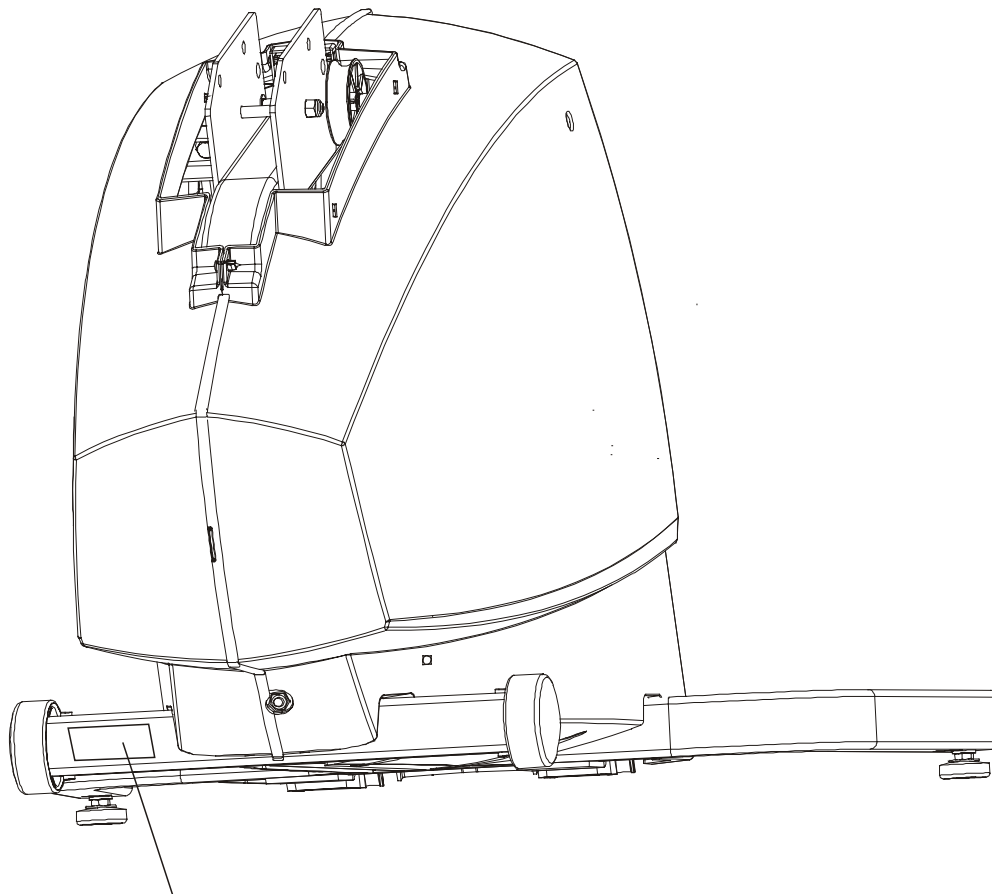

Serial Number/
Model Identification

PREVENTIVE MAINTENANCE SCHEDULE and SAFETY INSTRUCTIONS

COMPONENT	DAILY	MONTHLY	BI-MONTHLY
<i>Housing: Inside</i>			CLEAN
Outside	CLEAN		
Power Control Board			CLEAN
Heatsink			CLEAN
Connectors			INSPECT
Drive Belt			INSPECT
Alternator Belt			INSPECT
Clutches			INSPECT
Footpads		CLEAN	INSPECT
Cross-Over Pulleys			INSPECT
Lifepulse Sensors	CLEAN		INSPECT
Display	CLEAN		
Heart Rate Sensor Hardware			INSPECT

IMPORTANT SAFETY INSTRUCTIONS!

- ⇒ **DO NOT** locate the Stairclimber outdoors, near swimming pools, or in areas of high humidity.
- ⇒ **DO NOT** operate your Stairclimber if it has been dropped, damaged, or even partially immersed in water. If this occurs, contact Life Fitness Customer Support Services at the number in the Operation Manual.
- ⇒ **DO NOT** locate the Stairclimber any closer than 30 inches (76 cm) to a television set.
- ⇒ **DO NOT** locate additional Stairclimbers any closer than a minimum of 42 inches (107 cm) from center to center to avoid interference (cross talk) between Heart Rate monitors.
- ⇒ **DO** keep the area around your Stairclimber clear of any obstructions, including walls and furniture.
- ⇒ **DO** verify the contents of the delivery carton against the accompanying Parts Listing prior to setting the cartons and shipping material aside. If any parts are missing, contact Life Fitness Customer Support Services at the number listed in the Operation Manual. Save the shipping cartons in case of return.
- ⇒ **DO** read the entire Operation Manual prior to attempting to operate this machine as this is essential for proper use.

Life Fitness

©2000 Brunswick Corporation. All rights reserved. Life Fitness and Lifecycle are registered trademarks of Brunswick Corporation. Lifepulse, Zone Trainer and Heart Rate Zone Training are trademarks of Brunswick Corporation. Any use of these trademarks, without the express written consent of Brunswick Corporation, is forbidden.

M051-00K47-A013

March 2004